



EVENTS

D320L DIGITIZER

INSTALLATION GUIDELINES

Barco nv Events

Noordlaan 5, B-8520 Kuurne

Phone: +32 56.36.89.70

Fax: +32 56.36.88.24

E-mail: events@barco.com

Visit us at the web: www.barco.com

Printed in Belgium

Changes

Barco provides this manual “as is” without warranty of any kind, either expressed or implied, including but not limited to the implied warranties or merchantability and fitness for a particular purpose. Barco may make improvements and/or changes to the product(s) and/or the program(s) described in this publication at any time without notice.

This publication could contain technical inaccuracies or typographical errors. Changes are periodically made to the information in this publication; these changes are incorporated in new editions of this publication.

Copyright ©

All rights reserved. No part of this document may be copied, reproduced or translated. It shall not otherwise be recorded, transmitted or stored in a retrieval system without the prior written consent of BARCO.

Federal Communication Commission (FCC Statement)

This equipment has been tested and found to comply with the limits for a class A digital device, pursuant to Part 15 of the FCC rules. These limits are designed to provide reasonable protection against harmful interference when the equipment is operated in a commercial environment. This equipment generates, uses, and can radiate radio frequency energy and, if not installed and used in accordance with the instruction manual, may cause harmful interference to radio communications. Operation of this equipment in a residential area may cause harmful interference, in which case the user will be responsible for correcting any interference.

Trademarks

Brand and product names mentioned in this manual may be trademarks, registered trademarks or copyrights of their respective holders. All brand and product names mentioned in this manual serve as comments or examples and are not to be understood as advertising for the products or their manufactures.

Guarantee and Compensation

Barco provides a guarantee relating to perfect manufacturing as part of the legally stipulated terms of guarantee. On receipt, the purchaser must immediately inspect all delivered goods for damage incurred during transport, as well as for material and manufacturing faults Barco must be informed immediately in writing of any complaints.

The period of guarantee begins on the date of transfer of risks, in the case of special systems and software on the date of commissioning, at latest 30 days after the transfer of risks. In the event of justified notice of compliant, Barco can repair the fault or provide a replacement at its own discretion within an appropriate period. If this measure proves to be impossible or unsuccessful, the purchaser can demand a reduction in the purchase price or cancellation of the contract. All other claims, in particular those relating to compensation for direct or indirect damage, and also damage attributed to the operation of software as well as to other services provided by Barco, being a component of the system or independent service, will be deemed invalid provided the damage is not proven to be attributed to the absence of properties guaranteed in writing or due to the intent or gross negligence or part of Barco.

If the purchaser or a third party carries out modifications or repairs on good delivered by Barco, or if the goods are handled incorrectly, in particular if the systems are commissioned operated incorrectly or if, after the transfer of risks, the goods are subject to influences not agreed upon in the contract, all guarantee claims of the purchaser will be rendered invalid. Not included in the guarantee coverage are system failures which are attributed to programs or special electronic circuitry provided by the purchaser, e.g. interfaces. Normal wear as well as normal maintenance are not subject to the guarantee provided by Barco either.

The environmental conditions as well as the servicing and maintenance regulations specified in the this manual must be complied with by the customer.

TABLE OF CONTENTS

1. Safety	3
1.1 Important Safety Instructions	3
1.2 Important Warnings	4
2. Introduction	7
2.1 General functionality	7
2.2 Order info D320L Digitizer	7
2.3 Technical summary	7
2.4 Dimensions of the D320L Digitizer	8
3. Physical Installation of the D320L Digitizer	9
3.1 Installation requirements	9
3.2 Connections	10
3.3 Removing and inserting a D320L Digitizer input module	11
4. Input modules	13
4.1 DVI input module	13
4.2 SDI input module	14
4.3 HDSDI input module	14
4.4 CVBS / S-VID input module	16
4.5 YUV / RG(s)B input module	16
4.6 RGB analog input module	17
4.7 Dummy input module	18
5. Cables and accessories for the D320L Digitizer	19
5.1 Cables and accessories	19
6. Configuration schemes	21
6.1 Stand alone configuration	21
6.2 Chaining configuration	21
6.3 Stacking configuration	22
6.4 Combined chained and stacked configuration	23
7. Control Software	25
7.1 XLite Toolset	25
7.2 Version Control Manager (VCM)	25
8. Maintenance of the D320L Digitizer	27
8.1 Cleaning the dust filter	27
8.2 Cleaning the cabinet	27
9. Options	29
9.1 Overview	29
Index	31

1. SAFETY

1.1 Important Safety Instructions

Instructions:

- Read these instructions.
- Keep these instructions.
- Heed all warnings.
- Follow all instructions.
- Do NOT submerge fully or partly in water or other liquids.
- Clean only with materials or chemicals that are inert, nonabrasive, noncorrosive and non-marking. Consult the manufacturer for further advice should any doubts exist regarding any cleaning procedure.
- Do not block ventilation openings. Install in accordance with the manufacturers instructions.
- Do not install near any heat sources such as radiators, heat registers, stoves, or other apparatus (including amplifiers) that produce heat.
- Do not defeat the safety purpose of the polarized or grounding type plugs/sockets. If the provided sockets / plugs are damaged then replacement of the defective parts must be undertaken immediately.
- Protect the power/data cords from being walked on or pinched particularly at plugs, convenience receptacles, and the point where they exit from the apparatus. Replace damaged power/data cords immediately.
- Only use attachments/accessories specified by the manufacturer.
- Disconnect the power to this apparatus during lightning storms or provide suitable additional lightning protection. Unplug this apparatus when unused for long period of time.
- Refer all servicing to qualified service technicians/personnel. Servicing is required when the apparatus has been damaged in any way, such as power-supply cord or plug is damaged, the apparatus does not operate normally, or has been dropped.
- Use only with systems or peripherals specified by the manufacturer, or sold with the apparatus. Use caution during lifting/moving or transporting to avoid damage by possible tipping.

1.2 Important Warnings

Important Warnings:

- **Risk of electric shock:**

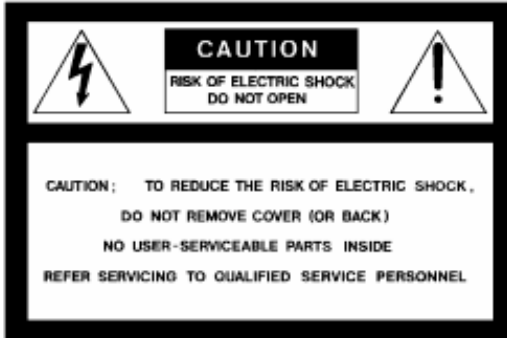

Image 1-1
Risk of electrical shock

Risk of electric shock. Do not open. To reduce the risk of electric shock, do not remove cover (or back). No user-serviceable parts inside. Refer servicing to qualified service personnel.

The lightning flash with an arrowhead within a triangle is intended to tell the user that parts inside this product may cause a risk of electrical shock to persons.

The exclamation point within a triangle is intended to tell the user that important operating and/or servicing instructions are included in the technical documentation for this equipment.

- **Maximum ambient temperature:**
The maximum recommended ambient temperature for this equipment is 40 °C.
- **Flammable materials:**
Keep flammable materials away from the installation (such as curtains). A lot of energy is transferred into heat. The installation should be such that the amount of air flow required for safe operation of the equipment is not compromised. Proper ventilation must be provided.
- **This equipment MUST be earthed:**
In order to protect against risk of electric shock, the installation should be properly grounded. Defeating the purpose of the grounding type plug will expose you to the risk of electric shock. This apparatus must be grounded (earthed) via the supplied 3 conductor AC power cord. (If the supplied power cord is not the correct variant, consult your dealer.)
- **Power system:**
It is recommended to use a TN-S power distribution system (a power distribution system with a separate neutral and grounding conductor) in order to avoid large ground currents loops due to voltage differences in the neutral conductor. The total electrical installation should be protected by an appropriate rated disconnect switch, circuit breakers and Ground Fault Current Interrupters. The installation shall be done according to the local electrical installation codes. In Europe special attention should be given to EN 60364, the standard for electrical installation of buildings. In Germany VDE 0100 should be adhered to.
- **Mains cords:**
The power cords delivered with this system have special properties for safety. They are not user serviceable. If the power cords are damaged, replace only with new ones. Never try to repair a power cord.

- **Use of an extension cord:**

If an extension cord is used with this product, make sure that the total of the ampere ratings on the products plugged into the extension cord does not exceed the extension cord ampere rating. Also make sure that the total of all products plugged into the wall outlet does not exceed 15 amperes.

- **Cabinet openings:**

Never push objects of any kind into this product through cabinet slots as they may touch dangerous high voltage points or short out parts that could result in a risk of fire or electrical shock.

Never spill liquid of any kind on the product. Should any liquid or solid object fall into the cabinet, unplug the set and have it checked by qualified service personnel before resuming operations.

1. Safety

2. INTRODUCTION

2.1 General functionality

Overview

The D320L is a video processing device, designed to drive exclusively Barco LED walls. The D320L is capable of handling all standard output formats like SVGA, XGA, SXGA and UXGA on an analog RGBHV and digital DVI output.

The D320L Digitizer allows you to control up to 4 sources on one display. Seamless switch from source to source or display sources together, overlay them, customize them. With analog and digital outputs which allow for the control of displays, as well as built-in-control software, the D320L gives you control over everything from basic set-up to configuration and advanced feature control.

The D320L Digitizer is a generic device. This means that a number of combinations can be made. Devices can be chained in order to generate more windows on the output (4 windows per device). Devices can also be stacked in order to be able to split generated output of the devices to multiple screens. For latter purpose, each input is equipped with an active loop through.

2.2 Order info D320L Digitizer

Order info:

Article No.	Description
R9851570	D320L Digitizer

2.3 Technical summary

Summary

Type	Value
Input slots	4 input slots, front accessible, auto sensing and hot swappable
Compatibility	Barco LED walls
Output	DVI-A, Barco LED protocol
Scalability	Chaining for more inputs, stacking for more displays
Flexibility	User defined input
Scaler	4 input channels [Data-Video] fully independent scalable to desired output resolution
Z-order control	Instant modification of Z-order control, for each output window
Window Positioning	Intuitive positioning interface
Connectors	RS 232 [RJ 11] — Ethernet [RJ 45]

2. Introduction

Type	Value
Effects	Anamorphic imaging, Chroma keying [per input], Alpha keying [per input], Z-order control, Windowing/ View ports
Ruggedness	IP 10
Dimensions D320L	486 x 482 x 53 (W x D x H)
Dimensions D320L input Units	41 x 181 x 103 (W x D x H)
Weight	± 7 kg
Operating Temperature	0 °C <> 45 °C
Power consumption	130 Watt max at 85–264 Volt (50–60 Hertz)
Stacking	Up to 64 units (for 64 different displays)
Chaining	Up to 64 units (for 256 inputs)

2.4 Dimensions of the D320L Digitizer

Dimensions

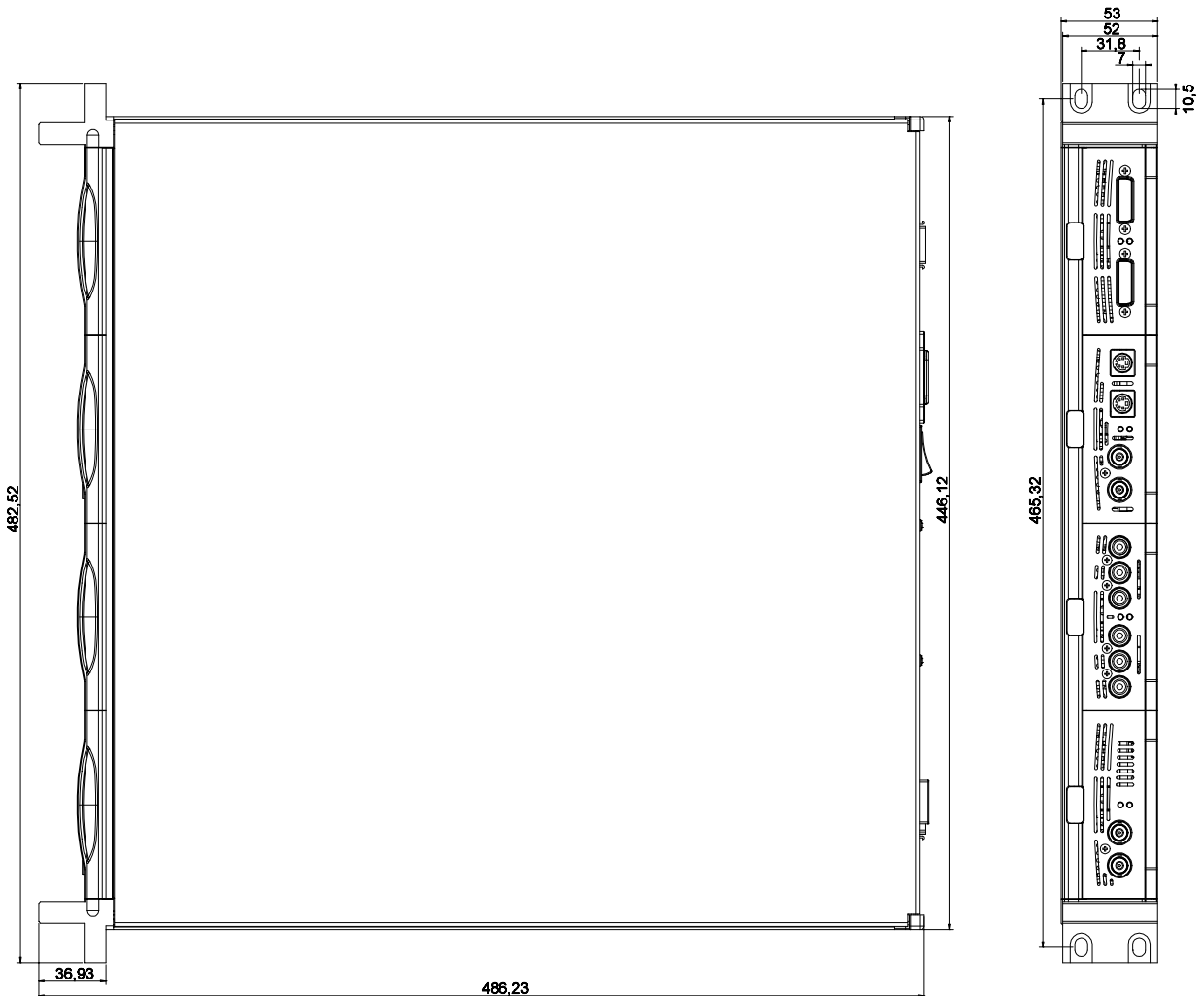

Image 2-1

3. PHYSICAL INSTALLATION OF THE D320L DIGITIZER

3.1 Installation requirements

Requirements

- The D320L Digitizer should not be placed in a built-in installation or enclosure unless proper ventilation is provided.
- When using the unit in a multi-unit rack assembly or closed assembly, the ambient temperature inside the assembly may not exceed the maximum rated ambient temperature of the Digitizer. The installation should be such that the amount of air flow required for safe operation of the equipment is not compromised.
- When building in the D320L Digitizer into a rack with cover door, be aware that a space of 8,5 cm is needed between the indicated reference and the cover door. This space is needed to guide the input cables to the inputs.

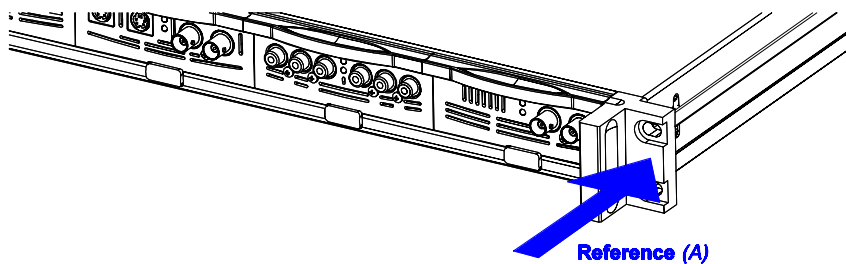

Image 3-1

A Reference

- The D320L Digitizer will require that air flows freely in vent holes. Blocking these holes will greatly reduce the reliability of the unit and lead to the possibility of overheating.
- The D320L Digitizer should operate from an AC power source. The D320L Digitizer is equipped with Power Supply Autoranging from 85 to 264 volt (50–60 Hertz).
- When installed in a rack, the mounting should be such that no hazardous condition is achieved due to uneven mechanical loading.
- When the mains switch located on the back of the D320L Digitizer is not accessible due to rack mounting, the socket outlet supplying the rack shall be installed near the equipment and be easily accessible or a readily accessible disconnect device shall be incorporated in the fixed wiring. When using a rack in an installation is advisable to log the serial number of the device and to activate the warranty figure by registering utilizing the included form.
- Do not place the D320L Digitizer on an unstable cart, stand or table. The device may fall, causing serious damage to it.

3.2 Connections

Rear panel inputs/outputs

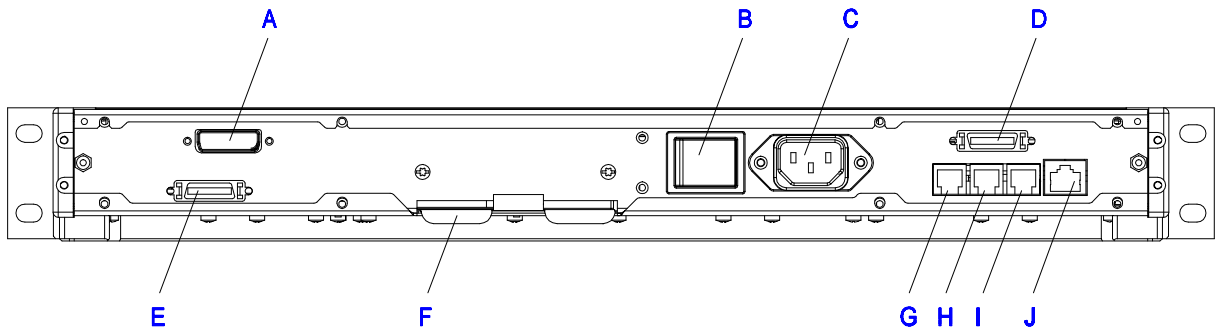

Image 3-2

- A LED-WALL OUTPUT
- B Power Switch
- C Power input
- D LOOP IN
- E LOOP OUT
- F Retractable dust filter
- G COM1 : RS232 input
- H COM2 : RS232 chaining output
- I COM3 : RS232 stacking output
- J TCP-IP : Ethernet LAN connector

- **A : LED-WALL OUTPUT**
 - LED wall out (Barco proprietary protocol).
 - RGB HV out (analog).
- **B : Power switch**
 - The power ON/OFF switch is provide on the rear side of the Digitizer.
 - Switch pressed to 1 = the unit starts.
 - Switch pressed to 0 = unit totally switched off.
- **C : Power input**
 - Autoranging from 90 to 260 VAC / 130 Watt.
- **D : LOOP IN**
 - From previous D320L Digitizer.
 - Panel Link MDR26.
 - Used for chaining multiple D320L digitizer to increase the number of usable input sources.
- **E : LOOP OUT**
 - To next Digitizer.
 - Panel Link MDR26.
 - Used for chaining multiple digitizer to increase the number of usable input sources.
- **F : Retractable dust filter**
 - The fan intake grill of the Digitizer has a retractable dust filter. This filter can be retracted from the back of the unit. Check the filter for good functionality on a regular basis. Never allow this filter to become blocked up and never operate the unit without a good working air filter in place.
- **G : COM1 : RS232 input**
 - Direct master.
 - RS232 input port for communication links with local PC.
- **H : COM2 : RS232 chaining output**
 - RS232 output port for communication links from other D320L Digitizers in chain configuration
- **I : COM3 : RS232 stacking output**
 - RS232 output port for communication links from other D320L Digitizers in stacking configuration.
- **J : TCP-IP : Ethernet LAN connector**
 - For future use.

3.3 Removing and inserting a D320L Digitizer input module



There is no need to switch off the D320L Digitizer to remove or insert an input module. The input modules are hot swappable.

How to remove an input module from the D320L Digitizer

1. Push in the release button underneath the input module which you want to remove. At the same time pull out the input module by the grip handle. (image 3-3)

3. Physical Installation of the D320L Digitizer

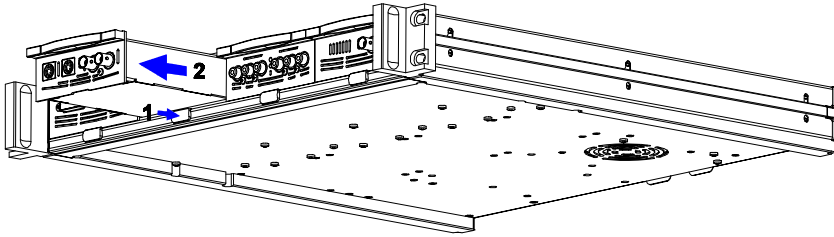

Image 3-3

How to insert an input module into the D320L Digitizer

1. Gently slide in the input module into a free input slot with the grip handle at the top.
2. Locking in the module by pushing the input module completely into the D320L Digitizer until a definite click is audible.



Maximum two HDSDI input modules may be inserted in one D320L Digitizer.

4. INPUT MODULES

Overview

- DVI input module
- SDI input module
- HDSDI input module
- CVBS / S-VID input module
- YUV / RG(s)B input module
- RGB analog input module
- Dummy input module

4.1 DVI input module

Technical info:

- Computer generated graphical source.
- DVI data in.
- 162 MHz pixel clock.
- Resolution from VGA to UXGA/60 Hz.
- DVI compliant.
- DVI loop through.
- Amber LED (upper LED on the front side) will be lit indicating module start up.
- When placed in an input slot the green LED (lower LED on the front side) will be lit indicating that the system acknowledges the module.



Image 4-1

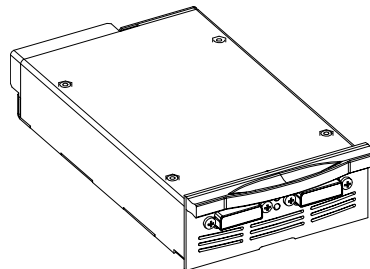

Image 4-2

Order info:

Article No.	Description
R9850960	D320L Digitizer DVI input module

4. Input modules

4.2 SDI input module

Technical info:

- SDI data in.
- SDI loop through.
- 270Mbit/s transmission (SMPTE 259M-C).
- 525/625 interlaced.
- Coax (75 Ohm).
- Amber LED (upper LED on the front side) will be lit indicating recognition of film, either continuous or intermittent film detection.
- When placed in an input slot the green LED (lower LED on the front side) will be lit indicating that the system acknowledges the module.

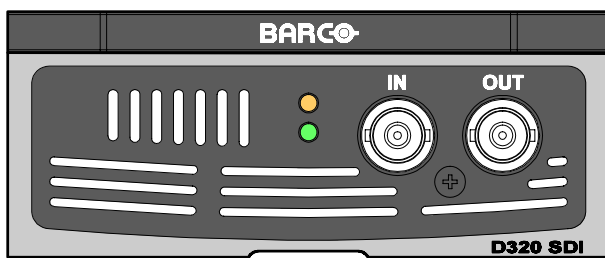

Image 4-3

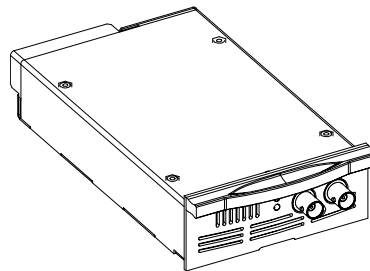

Image 4-4

Order info:

Article No.	Description
R9850970	D320L Digitizer SDI input module

4.3 HDSDI input module



Maximum two HDSDI input modules may be inserted in one D320L Digitizer.

Technical info:

- HDSDI data in (SMPTE292M).
- HDSDI loop through (SMPTE292M).
- Coax (75 Ohm).
- When placed in an input slot the green LED (lower LED on the front side) will be lit indicating that the system acknowledges the module.
- Supported HDSDI standards:
 - Progressive:
 - 1280x720/60/1:1/ (SMPTE 296M)
 - 1280x720/59.94/1:1/ (SMPTE 296M)
 - 1920x1080/30/1:1/ (SMPTE 274M)
 - 1920x1080/29.97/1:1/ (SMPTE 274M)
 - 1920x1080/25/1:1/ (SMPTE 274M)
 - 1920x1080/24/1:1/ (SMPTE 274M)
 - 1920x1080/23.98/1:1/ (SMPTE 274M)
 - Interlaced:
 - 1920x1035/60/2:1/ (SMPTE 260M)
 - 1920x1035/59.94/2:1/ (SMPTE 260M)
 - 1920x1080/60/2:1/ (SMPTE 274M)
 - 1920x1080/59.94/2:1/ (SMPTE 274M)
 - 1920x1080/50/2:1/ (SMPTE 274M)
 - 1920/1080/50/2:1 (1250)/ (SMPTE 295M)
 - 1920x1080/24/Segmented/ (SMPTE 274M)
 - 1920x1080//23.98/Segmented/ (SMPTE 274M)

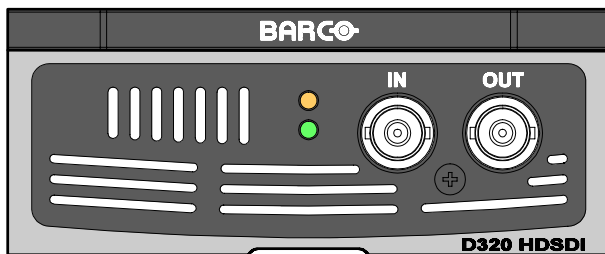

Image 4-5

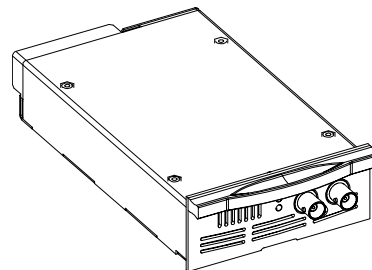

Image 4-6

Order info:

Article No.	Description
R9850980	D320L Digitizer HDSDI input module

4.4 CVBS / S-VID input module

Technical info:

- Video (BNC)
 - CVBS : 1Vpp \pm 3dB (0,7V Video +0,3V Sync) 75 Ohm termination.
 - BNC loop through connector.
- S-Video (4 pins DIN)
 - Y : 1Vpp \pm 3dB (0,7V Video +0,3V Sync) 75 Ohm termination.
 - U/V : 0,7Vpp \pm 3dB 100% color base, 75 Ohm termination.
 - Chroma : Multi-Standard (PAL / SECAM / NTSC).
 - 4 pins DIN loop through connector.
- Amber LED (upper LED on the front side) will be lit indicating recognition of film, either continuous or intermittent film detection.
- When placed in an input slot the green LED (lower LED on the front side) will be lit indicating that the system acknowledges the module.



Image 4-7

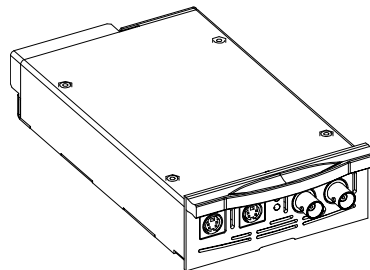

Image 4-8

Order info:

Article No.	Description
R9850920	D320L Digitizer CVBS / S-VID input module

4.5 YUV / RG(s)B input module

Technical info:

- Component Video (BNC)
 - R-Y : 0,7Vpp \pm 3dB 75 Ohm termination.
 - Ys : 1Vpp \pm 3dB (0,7V Luma +0,3V Sync) 75 Ohm termination.
 - B-Y : 0,7Vpp \pm 3dB 75 Ohm termination.
- RG(s)B (BNC)
 - R : 0,7Vpp \pm 3dB 75 Ohm termination.
 - G(s) : 1Vpp \pm 3dB (0,7Vpp G + 0,3Vpp Sync) 75 Ohm termination.
 - B : 0,7Vpp \pm 3dB 75 Ohm termination.
- 3 BNC's loop through connectors.
- Amber LED (upper LED on the front side) will be lit indicating recognition of film, either continuous or intermittent film detection.
- When placed in an input slot the green LED (lower LED on the front side) will be lit indicating that the system acknowledges the module.

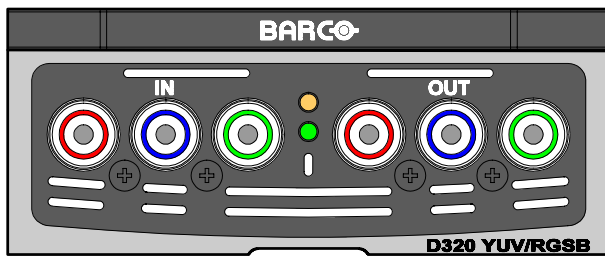

Image 4-9

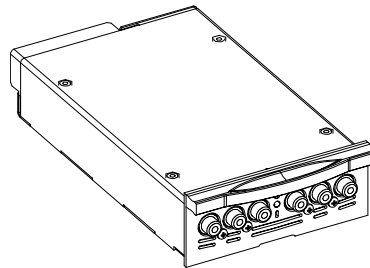

Image 4-10

Order info:

Article No.	Description
R9850940	D320L Digitizer YUV / RG(s)B input module

4.6 RGB analog input module

Technical info:

- Sub D15 connector for input and loop through.
- R, G, B, Hsync, Vsync : 0 to 1 Vpp ±3dB 75 Ohm termination.
- Black level : 300mV.
- Sync-tip : 0V
- Resolution : SXGA and UXGA version available.
- Amber LED (upper LED on the front side) will be lit indicating recognition of film, either continuous or intermittent film detection.
- When placed in an input slot the green LED (lower LED on the front side) will be lit indicating that the system acknowledges the module.

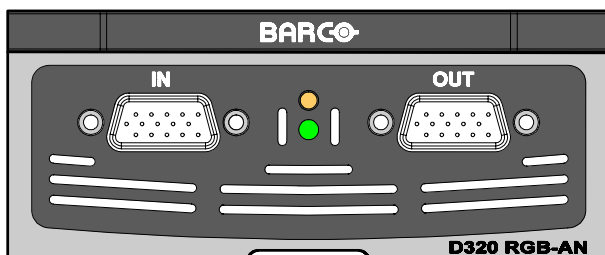

Image 4-11

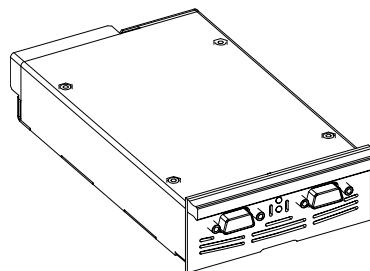

Image 4-12

Order info:

Article No.	Description
R9850950	D320L Digitizer RGB analog SXGA input module
R9851710	D320L Digitizer RGB analog UXGA input module

4.7 Dummy input module

Technical info

- Dimensions : 103 x 181 x 41(W x D x H)



Image 4-13

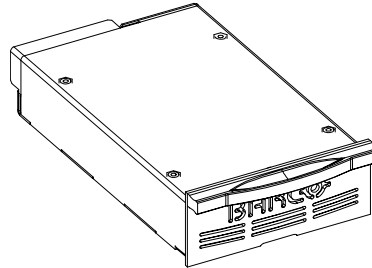

Image 4-14

Order info:

Article No.	Description
R9850930	D320L Digitizer dummy input module

5. CABLES AND ACCESSORIES FOR THE D320L DIGITIZER

5.1 Cables and accessories

List with available cables and accessories

Article No.	Description	Image
R326103	Power cable with CEE7 plug.	image 5-1
R3261115	Power cable with NEMA 5–15 plug.	image 5-2
B5580491	Data cable with RJ12 connectors for RS232 connection between local control PC and COM1 RS232 input port of the master Digitizer. Also used to connect the COM2 or COM3 port with the COM1 port of the following Digitizer.	image 5-3
Z3498421	RJ12–SUBD adapter.	image 5-4
R9827560	Data cable with SUBD connectors for RS232 connection between local control PC and COM1 RS232 input port of the master Digitizer.	image 5-5
Z3499209	One meter data cable with MDR connectors. Used to make a connection between the LOOP OUT connector of the previous Digitizer and the LOOP IN connector of the next Digitizer.	image 5-6
R9851210	Five meter data cable with DVI connectors. Used to connect the LED-WALL OUTPUT with an ILite display.	image 5-7
R9851216	Five meter data cable with one DVI connector and one waterproof MDR connector. Used to connect the LED-WALL OUTPUT with an DLite display.	image 5-8
R9851219	One meter data cable with one DVI connector and one MDR connector. Used to connect the LED-WALL OUTPUT with a Fiberlink Transmitter.	image 5-9



Image 5-1



Image 5-2



Image 5-3

5. Cables and accessories for the D320L Digitizer



Image 5-4



Image 5-5



Image 5-6



Image 5-7



Image 5-8



Image 5-9

6. CONFIGURATION SCHEMES

6.1 Stand alone configuration

Scheme



Image 6-1

One D320L Digitizer is sufficient to drive one Barco LED wall with four different sources.

How to set up a D320L stand alone configuration

1. Connect the RS232 communication port of the local control PC with the **COM1** RS232 input port of the D320L Digitizer.
2. Connect the **LED-WALL OUTPUT** from the D320L Digitizer with the display.
3. Provide the available video sources to the D320L input modules.
4. Configure the D320L Digitizer and the Display with the control software installed on the local control PC.

6.2 Chaining configuration

Scheme

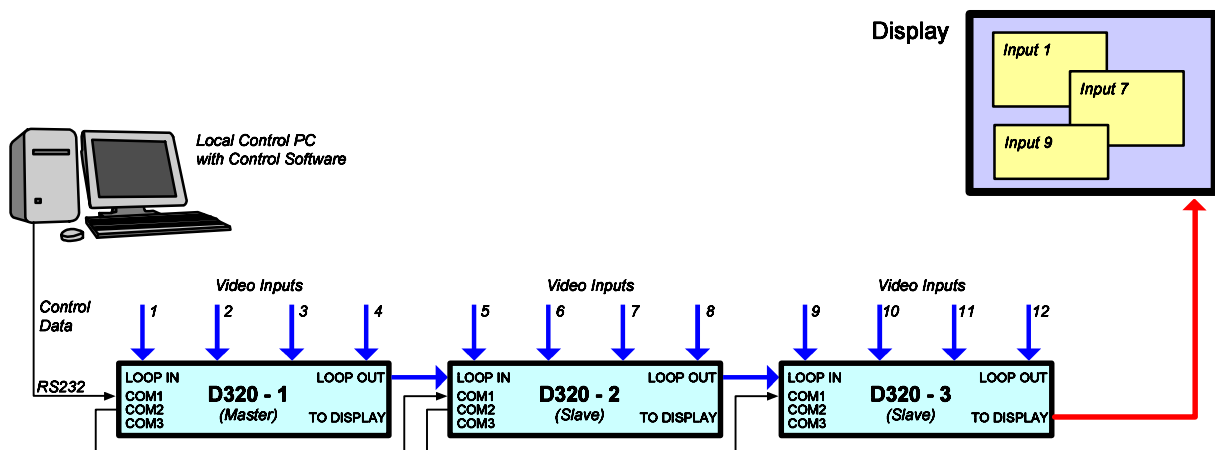

Image 6-2

6. Configuration schemes

The D320L Digitizer can be chained in order to generate more windows on the output display (four windows per D320L Digitizer).

How to set up a D320L chaining configuration

1. Connect the RS232 communication port of the local control PC with the **COM1** RS232 input port of the first D320L Digitizer. This Digitizer will act as the master, all following Digitizers are slaves.
2. Connect the **LOOP OUT** with the **LOOP IN** of the next D320L Digitizer in the chain.
3. Connect the **COM2** RS232 output port with the **COM1** RS232 input port of the next D320L Digitizer in the chain.
4. Repeat step 2 and 3 until all D320L Digitizers in the chain are connected.
5. Connect the **LED-WALL OUTPUT** from the last D320L Digitizer in the chain with the display.
6. Provide the available video sources to the input modules of the D320L Digitizers.
7. Configure the D320L Digitizers and the Display with the control software installed on the local control PC.

6.3 Stacking configuration

Scheme

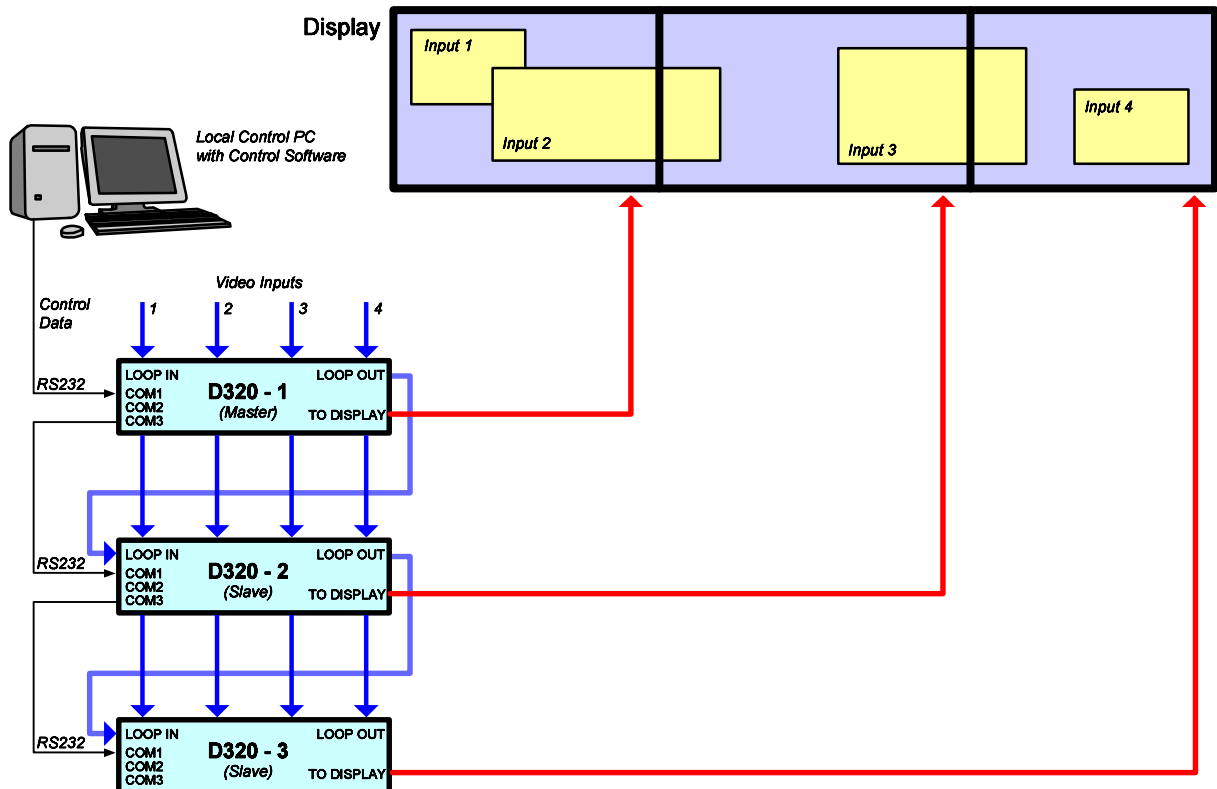

Image 6-3

For some large installations it is necessary to divide a complete large display into two or more screens depending on the used frame rate and the amount of pixels per line and the total lines of the complete display. For each screen a D320L Digitizer is used in stacking configuration. Consult Barco n.v. for advice about the number of D320L Digitizers to be stacked.

How to set up a mixed configuration

1. Connect the RS232 communication port of the local control PC with the **COM1** RS232 input port of the first D320L Digitizer. This Digitizer will act as the master, all following Digitizers are slaves.
2. Connect the **LOOP OUT** of each previous Digitizer with the **LOOP IN** of the next Digitizer.
3. Connect the **LED-WALL OUTPUT** of the last Digitizer of each chain with a screen. Do this in a logical order to simplify the configuration with the control software. First chain drives first screen from the left, second chain drives second screen from the left and so on.
4. Connect each **COM2** RS232 output port of the previous chained Digitizer with the **COM1** RS232 input port of the next chained Digitizer.
5. Connect each **COM3** RS232 output port of the previous stacked Digitizer with the **COM1** RS232 input port of the next stacked Digitizer.
6. Provide the available video sources to the input modules and use the active loop through to connect the sources with the other stacked input modules.
***Note:** The control software will recognize the chained Digitizers as one Digitizer in a stacked configuration. But instead of only 4 input slots the software will detect a plural of 4 input slots. Make sure the same input source is used for the same input slot number on the different stacked Digitizers.*
7. Configure the D320L Digitizers and the Display with the control software installed on the local control PC.

7. CONTROL SOFTWARE

7.1 XLite Toolset

General introduction

The XLite Toolset (R9850042) is used to configure and control the D320L Digitizer from basic set-up to advanced features such as chroma keying, alpha blending or window positioning. Refer to the manual (R5976380) for more information about the XLite Toolset.

7.2 Version Control Manager (VCM)

General introduction

The Version Control Manager (R9850044) is a stand alone program to update the software and firmware of D320L Digitizer. The software runs from CD-ROM and acts like a wizard. So no installation is required. The software runs on a Windows platform. Refer to the manual (R5976407) for more information about the Version Control Manager.

8. MAINTENANCE OF THE D320L DIGITIZER

8.1 Cleaning the dust filter



The fan intake grill of the D320L Digitizer has a retractable dust filter which must be checked for good functionality on regular basis. Never allow this filter to become blocked up.

How to clean the dust filter

1. Softly press down the lid of the dust filter at the rear side of the D320L Digitizer and pull out the filter. (image 8-1)
2. Blow out all the dust from the filter and remove remaining dust with a dry cloth.
3. Place the clean dust filter back in the D320L Digitizer.

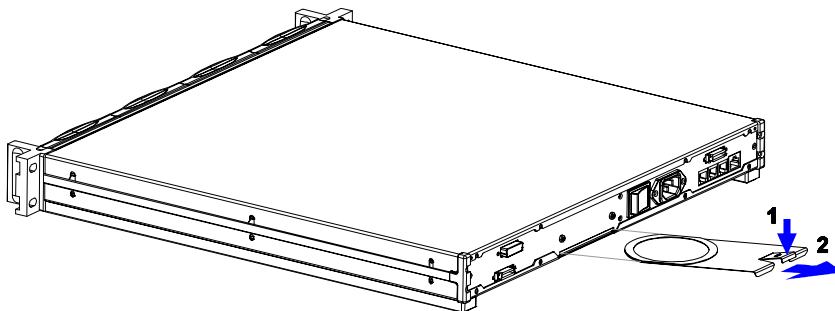

Image 8-1

8.2 Cleaning the cabinet



Do not use liquid cleaners or aerosol cleaners. Never use strong solvents, such as thinner or benzene, or abrasive cleaners, since these will damage the cabinet.

How to clean the cabinet

1. Unplug the D320L Digitizer from the wall outlet before cleaning.
2. Clean the cabinet with a damp cloth. Stubborn stains may be removed with a cloth lightly dampened with mild detergent solution.



To keep the cabinet looking brand-new, periodically clean it with a soft dry cloth.

8. Maintenance of the D320L Digitizer

9. OPTIONS

9.1 Overview

Order info:

Article No.	Description
R9851510	Climate Control Case for using the D320L Digitizer outdoor

9. Options

INDEX

A

Accessories 19

C

Cables 19

Cleaning 27

Air dust filter 27

Cabinet 27

Configuration scheme 21–23

Chaining 21

Mixed 23

Stacking 22

Stand alone 21

Configuration schemes 21

Connections 10

D320L 10

D

D320L 7–9, 13, 29

Dimensions 8

Functionality 7

Input modules 13

Installation 9

Requirements 9

Options 29

Technical summary 7

I

Input module 11, 13–14, 16–18

CVBS / S-VID 16

Dummy 18

DVI 13

HDSDI 14

Insert 11

Remove 11

RGB analog 17

SDI 14

YUV / RG(s)B 16

Introduction 7

D320L 7

M

Maintenance 27

O

Options 29

D320 29

Order info 7

D320L 7

S

Safety 3–4

Important Instructions 3

Warnings 4

Software 25

D320L 25

VCM 25

XLite Toolset 25

Revision Sheet

To:

► **Barco nv Events/Documentation**

Noordlaan 5, B-8520 Kuurne

Phone: +32 56.36.89.70, Fax: +32 56.36.88.24

E-mail: antoon.dejaegher@barco.com, Web: www.barco.com

From: _____

Date: _____

Please correct the following points in this documentation (**R5976542/00**):

page

wrong

correct