



---

**Kramer Electronics Ltd.**

# **USER MANUAL**

## **Format Interfaces**

**Models:**

**FC-10**

**FC-10D**

**FC-19**

**FC-4041C**

**FC-4042**

**FC-4043**

**FC-4044**

**FC-4208**

**IMPORTANT: Before proceeding, please read paragraph entitled  
"Unpacking and Contents"**



---

## Table Of Contents

Section	Name	Page
<b>1</b>	<b>INTRODUCTION</b>	<b>2</b>
1.1	A Word on Format Interfaces	2
1.2	Factors Affecting Quality of Results	3
<b>2</b>	<b>SPECIFICATIONS</b>	<b>4</b>
<b>3</b>	<b>HOW DO I GET STARTED?</b>	<b>6</b>
<b>4</b>	<b>UNPACKING AND CONTENTS</b>	<b>6</b>
4.1	Optional Accessories	6
<b>5</b>	<b>FORMAT INTERFACES</b>	<b>7</b>
5.1	Getting to Know Your FC-10	7
5.2	Getting to Know Your FC-10D	8
5.3	Getting to Know Your FC-19	9
5.4	Getting to Know Your FC-4041C	10
5.5	Getting to Know Your FC-4042	11
5.6	Getting to Know Your FC-4043	12
5.7	Getting to Know Your FC-4044	13
5.8	Getting to Know Your FC-4208	14
<b>6</b>	<b>INSTALLATION</b>	<b>15</b>
6.1	Rack Mounting	15
<b>7</b>	<b>CONNECTING TO VIDEO DEVICES</b>	<b>15</b>
<b>8</b>	<b>CONNECTING TO AUDIO DEVICES (FC-4208 ONLY)</b>	<b>15</b>
<b>9</b>	<b>USING THE MACHINES</b>	<b>15</b>
9.1	Powering on the Machine	15
9.2	Composite/YC Video Selection (FC-19, FC-4043, FC-4044 only)	15
9.3	Adjusting the HUE (FC-4043, FC-4044 only)	15
9.4	Looping (FC-4041C only)	15
9.5	Audio Level Control (FC-4208 only)	16
<b>10</b>	<b>TYPICAL APPLICATIONS</b>	<b>16</b>
10.1	Interfacing Between Two Video Formats	16
10.2	Using PC Graphics in YC Production	16
10.3	Typical Composite/YC to Component/RGB Conversion	17
10.4	Integrating a Composite/RGB source Into a Composite/YC Switcher	18
10.5	Audio Format Conversion	19
<b>11</b>	<b>TAKING CARE OF YOUR MACHINE</b>	<b>20</b>
<b>12</b>	<b>TROUBLESHOOTING</b>	<b>21</b>
12.1	Power and Indicators	21
12.2	Video Signal	22
12.3	Audio Signal (FC-4208 only)	23



---

## List Of Illustrations

<b>Figure</b>		<b>Page</b>
1	FC-10 Front/Rear Panel Features	7
2	FC-10D Front/Rear Panel Features	8
3	FC-19 Front/Rear Panel Features	9
4	FC-4041C Front/Rear Panel Features	10
5	FC-4042 Front/Rear Panel Features	11
6	FC-4043 Front/Rear Panel Features	12
7	FC-4044 Front/Rear Panel Features	13
8	FC-4208 Front/Rear Panel Features	14
9	Interfacing Between Two Video Formats	16
10	Using PC Graphics in YC Production	17
11	Typical PC/Presentation Product Connections	18
12	Integrating a Component/RGB source Into a Composite/YC Switcher	19
13	Audio Format Conversion	20
14	FC-10 and FC-10D Fuse Location	22

## List Of Tables

<b>Table</b>		<b>Page</b>
1	Factors Affecting Quality of Results	3
2	FC-10 Front/Rear Panel Features	7
3	FC-10D Front/Rear Panel Features	8
4	FC-19 Front/Rear Panel Features	9
5	FC-4041C Front/Rear Panel Features	10
6	FC-4042 - Front/Rear Panel Features	11
7	FC-4043 - Front/Rear Panel Features	12
8	FC-4044- Front/Rear Panel Features	13
9	FC-4208 - Front/Rear Panel Features	14



## 1 INTRODUCTION

Congratulations on your purchase of this Kramer Electronics format interface. Since 1981, Kramer has been dedicated to the development and manufacture of high quality video/audio equipment. The Kramer line has become an integral part of many of the best production and presentation facilities around the world. In recent years, Kramer has redesigned and upgraded most of the line, making the best even better. Kramer's line of professional video/audio electronics is one of the most versatile and complete available, and is a true leader in terms of quality, workmanship, price/performance ratio and innovation. In addition to the Kramer line of high quality format interfaces, such as the one you have just purchased, Kramer also offers a full line of high quality distribution amplifiers, switchers, processors, controllers and computer-related products.

This manual includes configuration, operation and option information for the following products from the Kramer line of format interfaces. All these interfaces are similar in operation and features.

**FC-10 - Composite-YC Transcoder**

**FC-4042 - RGB Component Transcoder**

**FC-10D - Composite-YC Comb Filter/Transcoder**

**FC-4043 - CV/YC Component Transcoder**

**FC-19 - RGB Decoder**

**FC-4044 - Multistandard Decoder**

**FC-4041C - Genlock Component Encoder**

**FC-4208 - Balanced Audio Transcoder**

### 1.1 A Word on Format Interfaces

There are several video signal formats: Composite, Y/C, YUV (Y, R-Y, B-Y), RGB (S) analog and digital. Component analog video formats (YUV and RGB) are unmodulated signals, where the signal level represents the signal intensity, (e.g., 1 Volt of "Y" signal represents a maximum white level). Converting from YUV to RGB and vice versa does not involve modulation, and needs mainly an accurate matrix system. Composite video and Y/C (Super Video) contains chrominance (color) information, which is a modulated signal using the color subcarrier (3.58MHz in NTSC, 4.43MHz in PAL) as the carrier signal. Converting between Composite video and Y/C (and vice versa) involves adding or separating the color information from the luminance information. To convert from Composite and Y/C to Component video, a color encoder or color decoder is needed, with very complicated circuitry. The color encoder receives the component signal, and must create a chrominance signal by extracting the blue and red information from the component video signal and by modulating this information using the color subcarrier signal. The color decoder performs the opposite: it removes the color subcarrier and extracts the color difference signals to create the video "components".

The following format interfaces are described in this manual:

- ❖ **Video Decoders** - used to decode (convert) a composite video signal to Y/C and to decode a composite or Y/C signal to RGBS and/or Y, R-Y, B-Y.
- ❖ **Video Encoders** - used to create a chrominance signal from video components, e.g., to convert RGBS and/or Y, R-Y, and B-Y signals to composite video and Y/C.
- ❖ **Video Transcoders** - are bi-directional converters operating simultaneously in different directions, such as converting from RGBS to Y, R-Y, and B-Y in both directions in the same machine, going from composite to Y/C, bi-directionally or performing color decoding and encoding in the same machine at the same time.
- ❖ **Audio Transcoders** - used in audio and video production studios for converting from unbalanced low-level audio to balanced high-level audio, bi-directionally.



## 1.2 Factors Affecting Quality of Results

There are many factors affecting the quality of results when signals are transmitted from a source to an acceptor as described in Table 1:

**Table 1: Factors Affecting Quality of Results**

<b>FACTOR</b>	<b>EFFECT</b>
<b>Connection cables</b>	Low quality cables are susceptible to interference; they degrade signal quality due to poor matching and cause elevated noise levels. They should therefore be of the best quality.
<b>Sockets and connectors of the sources and acceptors</b>	So often ignored, they should be of highest quality, since "Zero Ohm" connection resistance is the objective. Sockets and connectors also must match the required impedance (75ohm in video). Cheap, low quality connectors tend to rust, thus causing breaks in the signal path
<b>Amplifying circuitry</b>	Must have quality performance when the desired end result is high linearity, low distortion and low noise operation
<b>Distance between sources and acceptors</b>	Plays a major role in the final result. For long distances between sources and acceptors, special measures should be taken in order to avoid cable losses. These include using higher quality cables or adding line amplifiers.
<b>Interference from neighboring electrical appliances</b>	These can have an adverse effect on signal quality. Balanced audio lines are less prone to interference, but unbalanced audio should be installed far from any mains power cables, electric motors, transmitters, etc. even when the cables are shielded



## 2 SPECIFICATIONS

	<b>FC-10</b>	<b>FC-10D</b>	<b>FC-19</b>	<b>FC-4041C</b>
Configuration	Transcoder	Comb Filter/Transcoder	RGB Decoder	Encoder
Inputs	1 Composite Video, 1Vpp/75 ohm on a BNC, 1 s-Video on a 4P connector, Y: 1Vpp/75ohm, C: 0.3Vpp/75ohm.	1 Composite Video, 1Vpp/75 ohm on a BNC, 1 s-Video on a 4P connector, Y: 1Vpp/75ohm, C: 0.3Vpp/75ohm.	1 Composite Video, 1Vpp/75 ohm on a BNC, 1 s-Video on a 4P connector, Y: 1Vpp/75ohm, C: 0.3Vpp/75ohm.	R (or R-Y), G (or Y), B (or B-Y) – 0.7Vpp/75 ohm, Sync looping – 0.3Vpp/75ohm on BNCs
Outputs	1 s-Video on a 4P connector, Y: 1Vpp/75ohm, C: 0.3Vpp/75ohm. 1 Composite Video, 1Vpp/75 ohm on a BNC.	1 s-Video on a 4P connector, Y: 1Vpp/75ohm, C: 0.3Vpp/75ohm. 1 Composite Video, 1Vpp/75 ohm on a BNC.	RED, GREEN, BLUE, SYNC, 0.7Vpp/75 ohms, on BNCs, RGB (Analog), HS, VS TTL level on HD15 connector	1 Composite Video, 1Vpp/75 ohm on a BNC, 1 s-Video on a 4P connector, Y: 1Vpp/75ohm, C: 0.3Vpp/75ohm.
Controls		Two electronic touch switches to select PAL or NTSC operation.	Rear input selector switch between Composite Video and s-Video	Sync/Sync on Green, input selector - RGBS or Y, R-Y, B-Y.
Video Bandwidth	10MHz -1dB	100 MHz -3dB (Y/C to CV), >5.8 MHz (CV to Y/C, PAL)	Luma: 10MHz -3dB	Exceeding 12MHz (Y)
Nonlinearity			< 3%	Less than 0.5dB
Residual SC.			-38dB	-34dB
DC Clamp				0 VDC Black Level.
Differential Gain	0.36%	0.7% (Y/C to CV, NTSC).		0.24%
Differential Phase	0.3Deg.	0.15Deg. (Y/C to CV, NTSC).		0.26Deg.
K-Factor	<0.05% (Y/C to CV).	<0.1% (Y/C to CV), <0.5% (CV to Y/C, NTSC).		
Luma S/N Ratio	79dB	>72dB in both directions, (PAL).	64dB	
RGB Balance Error			Less than 0.5dB	
Dimensions (W, D, H)	16.5 x 12 x 4.5 (cm) 6.5" x 4.7" x 1.8"	16.5 x 12 x 4.5 (cm) 6.5" x 4.7" x 1.8"	48 x 17.8 x 1U (cm) 19" x 7" x 1U.	48 x 17.8 x 1U (cm) 19" x 7" x 1U
Weight	0.6kg. (1.3lbs.) Approx.	0.64 kg. (1.4 lbs.) Approx.	2.5kg (5.5 lbs.) Approx.	2.6kg. (5.8lbs.) Approx.
Power Source	12VDC, 110mA	12VDC, 200mA	230 VAC, 50/60 Hz, (115VAC, U.S.A.) 12VA	230 VAC, 50/60 Hz, (115VAC, U.S.A.) 6 VA.



## SPECIFICATIONS (Continued)

	<b>FC-4042</b>	<b>FC-4043</b>	<b>FC-4044</b>	<b>FC-4208</b>
<b>Configuration</b>	Transcoder	Transcoder	Decoder	Audio Transcoder
<b>Inputs</b>	1 component (Y, R-Y, B-Y), 1V, 0.7V, 0.7 Vpp /75ohm, 1 RGBS 0.7Vpp / 75ohm, for 100% saturation on BNCs	Decoder: 1 Composite video, 1Vpp/75 ohms on a BNC, 1 s-Video: 1Vpp/75ohm (Y), 0.3Vpp/75ohm (C) on a 4P connector Encoder: 1 (Y, R-Y, B-Y) 1V, 0.7V, 0.7 Vpp /75ohm on BNCs	1 Composite video, 1Vpp/75 ohms on a BNC, 1 s-Video: 1Vpp/75ohm (Y), 0.3Vpp/75ohm (C) on a 4P connector	4 balanced, +4dBm /50kohm on female XLRs 4 unbalanced, 1Vpp / 50kohm on RCAs.
<b>Outputs</b>	1 RGB 0.7Vpp / 75ohm, Sync 2Vpp/75 ohms, TTL level unloaded, for 100% saturation on BNCs, 1 component (Y, R-Y, B-Y), 1V, 0.7V, 0.7 Vpp /75ohm, BNCs	Decoder: 1V, 0.7V, 0.7 Vpp /75ohm (Y, R-Y, B-Y), BNCs Encoder: 1Vpp/75ohm (Composite, BNC) Y/C: 1Vpp/75ohm (Y), 0.3Vpp/75ohm (C), 4P connector	Component: 1V, 0.7V, 0.7Vpp /75ohm, BNCs RGB: 0.7Vpp/75ohm, for 100% saturation, Composite sync: 2Vpp/75ohm, BNCs	4 unbalanced, 1Vpp/50 ohms, RCAs 4 balanced, +4dBm/50 ohms, 18Vpp max., male XLRs
<b>Diff. Gain</b>		0.21%		
<b>Diff. Phase</b>		0.19Deg.		
<b>K-Factor</b>	0.4%		1.2 %	
<b>Non Linearity</b>	Less than 0.2%		Less than 0.2%	
<b>DC Clamp Error</b>		±20 mV	±20 mV	
<b>Residual SC</b>		Composite to Y=30 mV, Y/C to Y = 15 mV	Composite to Y=30mV Y/C to Y = 15mV	
<b>Y S/N Ratio</b>	Better than 71dB			
<b>Audio Bandwidth</b>	NA	NA	NA	20-30000Hz
<b>Audio THD</b>	NA	NA	NA	Less than 0.02%
<b>Audio S/N Ratio</b>	NA	NA	NA	Better than 89dB
<b>Dimensions (W, D, H)</b>	48 x 17.8 x 1U (cm) 19" x 7" x 1U	48 x 17.8 x 1U (cm) 19" x 7" x 1U	48 x 17.8 x 1U (cm) 19" x 7" x 1U	48 x 17.8 x 1U (cm) 19" x 7" x 1U
<b>Weight</b>	2.6kg. (5.8lbs.) Approx.	2.6kg. (5.8lbs.) Approx.	2.6kg. (5.8lbs.) Approx.	2.4kg. (5.3lbs.) Approx.
<b>Power Source</b>	230VAC, 50/60Hz (115VAC, U.S.A.) 7.6VA	230VAC, 50/60Hz, (115VAC, U.S.A.) 19.5VA	230VAC, 50/60Hz, (115VAC, U.S.A.) 6.9VA	230VAC, 50/60Hz (115VAC, U.S.A.) 3.7VA



### 3 HOW DO I GET STARTED?

The fastest way to get started is to take your time and do everything right the first time. Taking 15 minutes to read the manual may save you a few hours later. You don't even have to read the whole manual. If a section doesn't apply to you, you don't have to spend your time reading it.

### 4 UNPACKING AND CONTENTS

The items contained in your Kramer Format interface package are listed below. Please save the original box and packaging materials for possible future transportation and shipment.

<b>Format Interface</b>	<b>User Manual</b>
<b>AC Power Cable (where applicable)</b>	<b>Kramer Concise Product Catalog</b>
<b>DC Power Supply (where applicable)</b>	<b>4 Rubber Feet</b>

#### 4.1 Optional Accessories

The following accessories, which are available from Kramer, can enhance implementation of your machine. For information regarding cables and additional accessories, contact your Kramer dealer.

- **Rack Mechanical Adapter** - Used to adapt smaller machines to a standard 1U rack. One or more machines may be installed on each adapter.
- **103AV** - (Video Audio Distribution Amplifier) can be serially connected between the Format interface and the acceptor for video distribution. The 103AV splits a single video and audio-stereo input source into three identical outputs. The 103AV uses an external 12VDC power source, and therefore is suitable for field work as well. The 103AV uses state of the art technology and microchip design, boasting a signal bandwidth of over 320MHz, thus making it suitable for the most demanding applications.
- **SP-11** - (Video/Audio Processor) can be serially connected between the video/audio source and the format interface for video and audio control/correction. The machine provides camera control and luminance/white balance correction. It is also capable of performing composite to Y/C conversion and bi-directional transcoding. The machine allows full control over the video signal: video gain down to full fade, log or linear definition control, log or linear contrast control, color saturation control, black level control, red, green and blue controls and a screen splitter control for "before-after" comparison. The Input switch control is "audio-follow-video".
- **VS-2042** - (4x2 Video Component Matrix) can be serially connected between the sources and the format interface for component video switching. The VS-2042 switches during the vertical interval for live studio operation. The VS-2042 has a built-in RS-232 interface for computer controlled operation, (software included) and several machines may be operated simultaneously via PC control. Its signal bandwidth exceeds 75MHz and it has DC coupled inputs and outputs for highest signal quality. Y, R-Y, B-Y or R, Gs, B signals are seamlessly routed.
- **VIDEO TESTER** - A new, unique, patented, indispensable tool for the video professional, the Video Tester is used to test a video path leading to/from an amplifier. By pressing only one touch switch it can trace missing signals, distinguish between good and jittery (VCR sourced) signals, and identify the presence of good signals. Whenever a video signal is missing, because of bad connections, cable breaks or faulty sources, the Video Tester is all you need.



## 5 FORMAT INTERFACES

This section describes all the controls and connections of your machine. Understanding the controls and connections helps you realize the full power of your machine.

### 5.1 Getting to Know Your FC-10

The KRAMER **FC-10** Composite-YC Transcoder is designed to interface between the two popular video formats: Composite Video and YC (Super-Video). Hardly any VCR or camcorder transcodes from Composite Video to Super-Video, although it is necessary when material shot in Composite is to be edited into a Y/C production. The Kramer **FC-10** is very small, and is fed from an external 12V DC supply, excellent for fieldwork. Front/Rear panel features of the **FC-10** are described in Figure 1 and Table 2.

#### NOTE

*For operation instructions refer to section 9.*

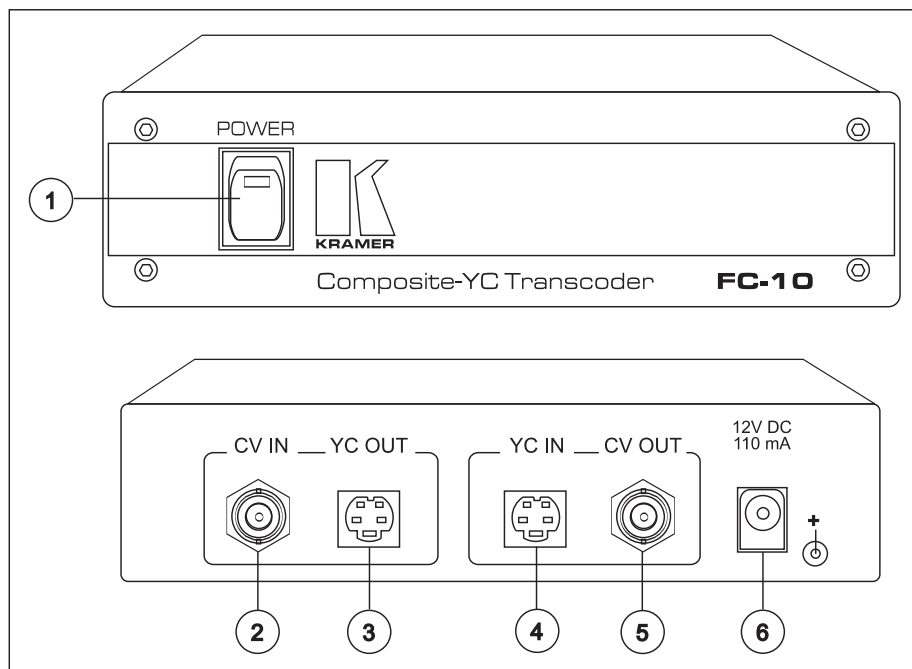

**Figure 1: FC-10 Front/Rear Panel Features**

**Table 2: FC-10 Front/Rear Panel Features**

	<b>Feature</b>	<b>Function</b>
<b>1.</b>	<b>Power Switch</b>	Illuminated switch supplies power to the unit.
<b>2.</b>	<b>CV IN BNC connector</b>	Composite video input.
<b>3.</b>	<b>YC OUT 4P connector</b>	s-Video output.
<b>4.</b>	<b>YC IN 4P connector</b>	s-Video input.
<b>5.</b>	<b>CV OUT BNC connector</b>	Composite video output.
<b>6.</b>	<b>12VDC feed connector</b>	A DC connector that allows power to be supplied to the unit.



## 5.2 Getting to Know Your FC-10D

The KRAMER **FC-10D** Composite-YC Comb Filter/Transcoder was designed to interface between the two popular video formats: Composite Video and YC (Super-Video). The decoding from composite to Y/C is done digitally using an adaptive comb filter and DSP techniques to minimize dot-crawl and cross-color. A built-in vertical enhancer circuit reduces noise and dot-crawl on the Y signal. In addition, the **FC-10D** provides an independent Y/C to Composite route, for simultaneous bi-directional operation. The Kramer **FC-10D** is very small in size, and is fed from an external 12VDC supply, ideal for fieldwork. Front/Rear panel features of the **FC-10D** are described in Figure 2 and Table 3.

### NOTE

For operation instructions refer to section 9.

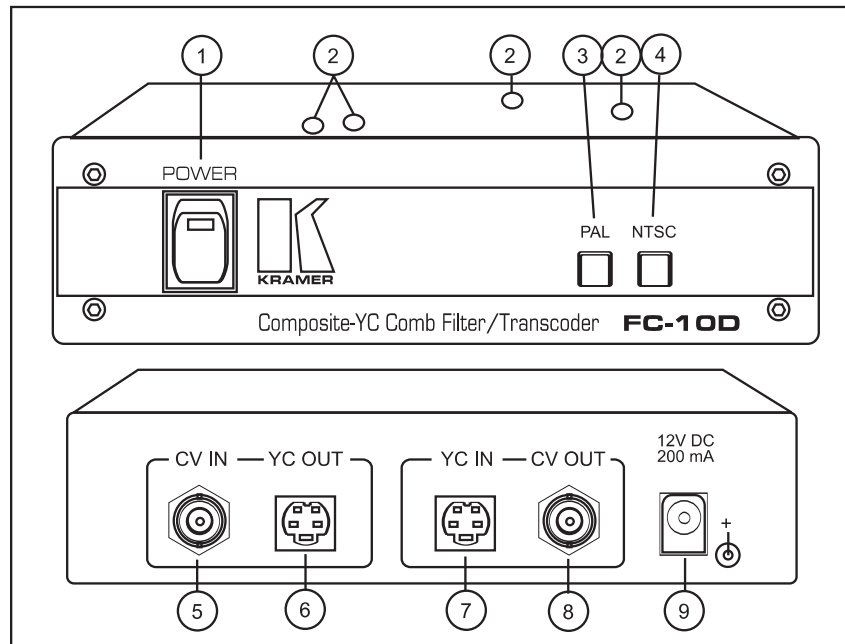

Figure 2: FC-10D Front/Rear Panel Features

Table 3: FC-10D Front/Rear Panel Features

	Feature	Function
1.	Power Switch	Illuminated switch supplies power to the unit.
2.	Internal trimmers (bottom accessible)	Not used. <b>WARNING!</b> Adjustments or attempted adjustments of the trimmers are not allowed. Failure to comply with this warning may damage the machine.
3.	PAL pushbutton	Illuminated pushbutton: selects PAL system when pressed.
4.	NTSC pushbutton	Illuminated pushbutton: selects NTSC system when pressed.
5.	CV IN BNC connector	Composite video input.
6.	YC OUT 4P connector	s-Video output.
7.	YC IN 4P connector	s-Video input.
8.	CV OUT BNC connector	Composite video output.
9.	12VDC feed connector	A DC connector that allows power to be supplied to the unit.



### 5.3 Getting to Know Your FC-19

The KRAMER FC-19 is an industrial level RGB Decoder, which converts both Composite Video and Super-Video to their RGB components. Front/Rear panel features of the FC-19 are described in Figure 3 and Table 4.

**NOTE**

*For operation instructions refer to section 9.*

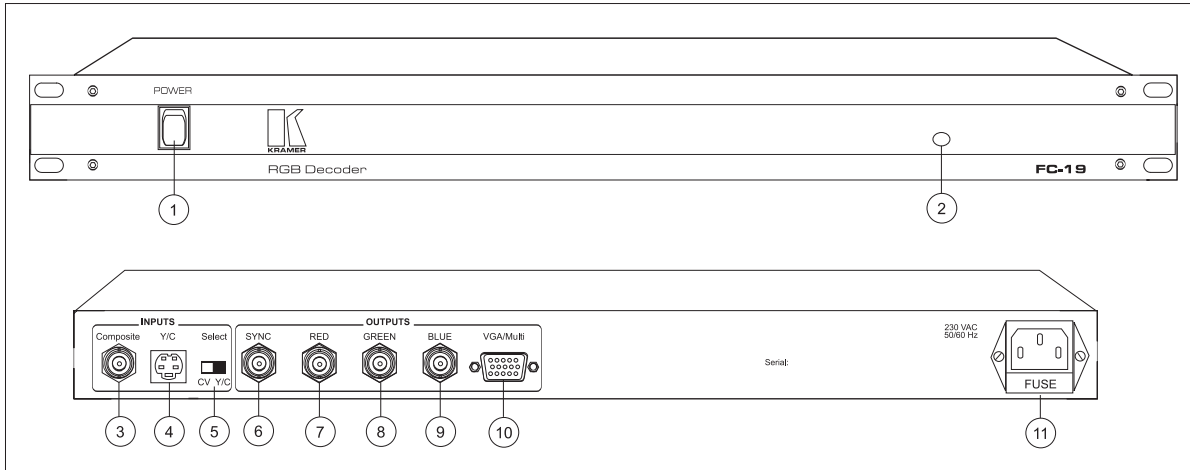

**Figure 3: FC-19 Front/Rear Panel Features**

**Table 4: FC-19 Front/Rear Panel Features**

	Feature	Function
1.	Power Switch	Illuminated switch supplies power to the unit.
2.	Internal trimmer (bottom accessible)	Not used.  <b>WARNING!</b> Adjustments or attempted adjustments of the trimmer are not allowed. Failure to comply with this warning may damage the machine.
3.	Composite BNC connector	Composite video input.
4.	YC 4P connector	s-Video input.
5.	Select CV/YC switch	Selects either Composite or s-Video to be converted.
6.	SYNC BNC connector	Sync signal output.
7.	RED BNC connector	RED signal output.
8.	GREEN BNC connector	GREEN signal output.
9.	BLUE BNC connector	BLUE signal output.
10.	VGA/Multi HD15 connector	VGA type signal output (horizontal sync frequency = 15kHz, no scan conversion.)
11.	Power Connector	A 3-prong AC connector allows power to be supplied to the unit. Directly underneath this connector, a fuse holder houses the appropriate fuse.



## 5.4 Getting to Know Your FC-4041C

The KRAMER FC-4041C is a full broadcast, state-of-the-art Genlock RGB/Component to Composite Video/YC Encoder designed for studio and other demanding applications. The FC-4041C encodes RGBS or Component Y, R-Y and B-Y signals to Composite Video and Super-Video signals. All inputs are looped through with termination switches, allowing for parallel connection to other RGBS/Component acceptors. From front panel switches, the FC-4041C allows the user to select whether Sync is separate or riding on Green. The user can also select whether to convert RGBS or Component signals to Composite and Y/C. The outputs are DC coupled and Black-Level clamped. Front/Rear panel features of the FC-4041C are described in Figure 4 and Table 5.

### NOTE

For operation instructions refer to section 9.

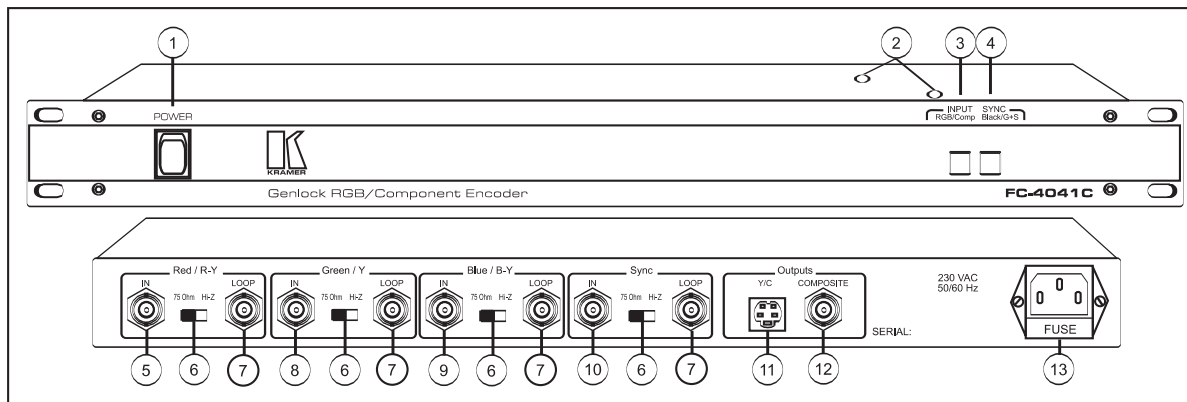

Figure 4: FC-4041C Front/Rear Panel Features

Table 5: FC-4041C Front/Rear Panel Features

	Feature	Function
1.	Power Switch	Illuminated switch supplies power to the unit.
2.	Trimmers	Not used.  <b>WARNING!</b> Adjustments or attempted adjustments of the trimmers are not allowed. Failure to comply with this warning may damage the machine.
3.	<b>INPUT RGB/Comp</b> pushbutton	Illuminated pushbutton: selecting RGB or Component input
4.	<b>SYNC Black/G+S</b> pushbutton	Illuminated pushbutton: selecting sync source – separate or riding on Green.
5.	<b>Red/R-Y IN</b> BNC connector	<b>Red/R-Y</b> Input
6.	<b>Red/Green/Blue 75 ohm/Hi-Z</b> selectors	Selects “75ohm” or “Hi-z” impedance when pushed in the selected direction (for looping select “Hi-z”).
7.	<b>Red/Green/Blue LOOP</b> BNC connector	Provides <b>Red/R-Y</b> looping capability to increase number of outputs.
8.	<b>Green/Y IN</b>	<b>Green/Y</b> Input
9.	<b>Blue/B-Y IN</b> BNC connector	<b>Blue/B-Y</b> Input
10.	<b>Sync IN</b> BNC connector	Sync signal input.
11.	<b>Y/C</b> 4P connector	s-Video output.
12.	<b>COMPOSITE</b> BNC connector	<b>Composite</b> video output.
13.	Power Connector	A 3-prong AC connector allows power to be supplied to the unit. Directly underneath this connector, a fuse holder houses the appropriate fuse.



## 5.5 Getting to Know Your FC-4042

The KRAMER **FC-4042** RGB-Component Transcoder interfaces between the two most widely used professional video formats: Component Video (Y, R-Y, B-Y) and RGBS. In many video studios and production centers there is a need to convert from one format to the other, and the Kramer **FC-4042** is the perfect choice as it operates simultaneously in both directions.

Front/Rear panel features of the **FC-4042** are described in Figure 5 and Table 6.

### NOTE

*For operation instructions refer to section 9.*

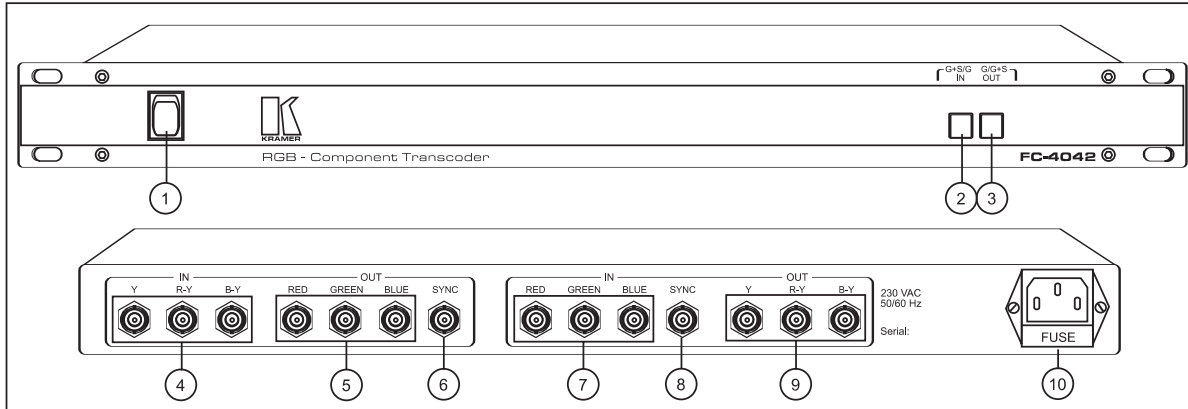

**Figure 5: FC-4042 Front/Rear Panel Features**

**Table 6: FC-4042 - Front/Rear Panel Features**

	Feature	Function
1.	Power Switch	Illuminated switch supplies power to the unit.
2.	G+S/G IN pushbutton	Selects sync or sync on green on the RGB signals for the "IN" channel.
3.	G/G+S OUT pushbutton	Selects sync or sync on green on the RGB signals for the " OUT " channel.
4.	IN Y, R-Y, B-Y BNC connectors	Component video inputs.
5.	OUT RED, GREEN, BLUE BNC connectors	RGB outputs.
6.	OUT SYNC BNC connector	Sync signal output.
7.	IN RED, GREEN, BLUE BNC connectors	RGB inputs.
8.	IN SYNC BNC connector	Sync signal input.
9.	OUT Y, R-Y, B-Y BNC connectors	Component video outputs.
10.	Power Connector	A 3-prong AC connector allows power to be supplied to the unit. Directly underneath this connector, a fuse holder houses the appropriate fuse.



## 5.6 Getting to Know Your FC-4043

The KRAMER **FC-4043** CV/YC - Component Transcoder interfaces between Composite video and Y/C to the most widely used professional video format - Component Video (Y, R-Y, B-Y) bi-directionally. In many video studios and production centers there is a need to convert from one format to the other, and the Kramer **FC-4043** is the perfect choice as it operates in the most common standards - PAL, SECAM and NTSC (both) – and bi-directionally. Decoding operation is microprocessor controlled via the internal I<sup>2</sup>C bus and the machine allows standards conversion between PAL and SECAM. Front/Rear panel features of the **FC-4042** are described in Figure 6 and Table 7.

### NOTE

For operation instructions refer to section 9.

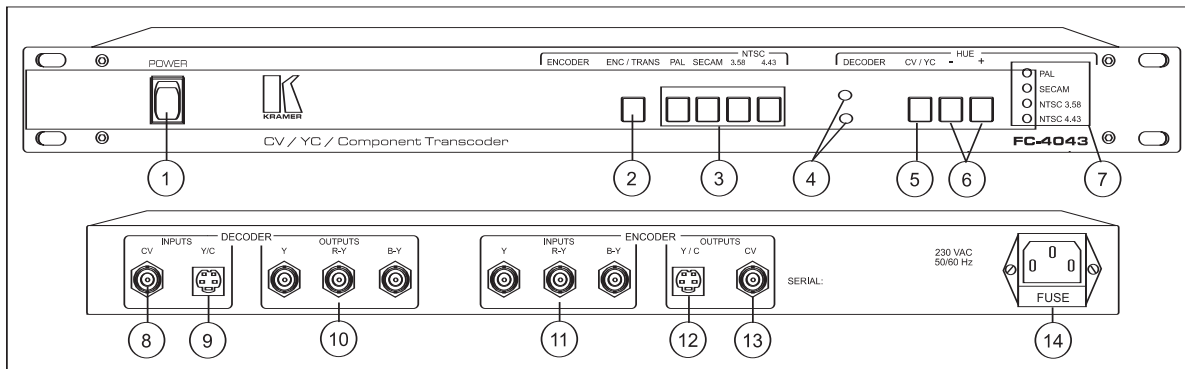

Figure 6: FC-4043 Front/Rear Panel Features

Table 7: FC-4043 - Front/Rear Panel Features

Feature	Function
1. Power Switch	Illuminated switch supplies power to the unit.
2. ENC/TRANS pushbutton	Encoder or Transcoder function selector. When Transcoder is selected (switch is not illuminated), an internal link is formed between the components outputs of the Decoder section and the component inputs of the Encoder section – allowing for example - Composite SECAM to PAL conversion (or vice versa)
3. PAL, SECAM, 3.58, 4.43 encoder pushbuttons	Illuminated pushbuttons: selecting the output encoding standard desired. Note that the machine does not scan convert between PAL and NTSC but can allow for NTSC 4.43 output from an NTSC 3.58 input for example.
4. Internal trimmers	Not used. <b>WARNING!</b> Adjustments or attempted adjustments of the trimmers are not allowed. Failure to comply with this warning may damage the machine.
5. CV/YC pushbutton	Illuminated pushbutton. Selects either composite video or Y/C signal at the decoder input when pressed.
6. HUE (+/-) pushbuttons	Only active when NTSC is used, for changing output picture hue.
7. PAL, SECAM, 3.58, 4.43 LEDS	Illuminates the appropriate LED when one of the corresponding standards input signal is auto detected (blinks when there is no input.)
8. INPUTS CV BNC connector	Composite video input to the Decoder.
9. INPUTS Y/C 4P connector	Y/C input to the Decoder.
10. OUTPUTS Y, R-Y, B-Y BNC connectors	Component video outputs from the Decoder.
11. INPUTS Y, R-Y, B-Y BNC connectors	Component video inputs to the Encoder.
12. OUTPUTS YC 4P connector	YC output from the Encoder.
13. OUTPUTS CV BNC connector	Composite video output from the Encoder.
14. Power Connector	A 3-prong AC connector allows power to be supplied to the unit. Directly underneath this connector, a fuse holder houses the appropriate fuse.



## 5.7 Getting to Know Your FC-4044

The KRAMER **FC-4044** Multistandard Decoder interfaces from Composite video and Y/C to the most widely used professional video formats - Component Video (Y, R-Y, B-Y) and RGBS. In many video studios and production centers there is a need to convert from one format to the other and the KRAMER **FC-4044** is the perfect choice as it operates in the most common standards - PAL, SECAM and NTSC (both). Decoding is microprocessor controlled via the internal I<sup>2</sup>C bus.

Front/Rear panel features of the **FC-4044** are described in Figure 7 and Table 8.

### NOTE

*For operation instructions refer to section 9.*

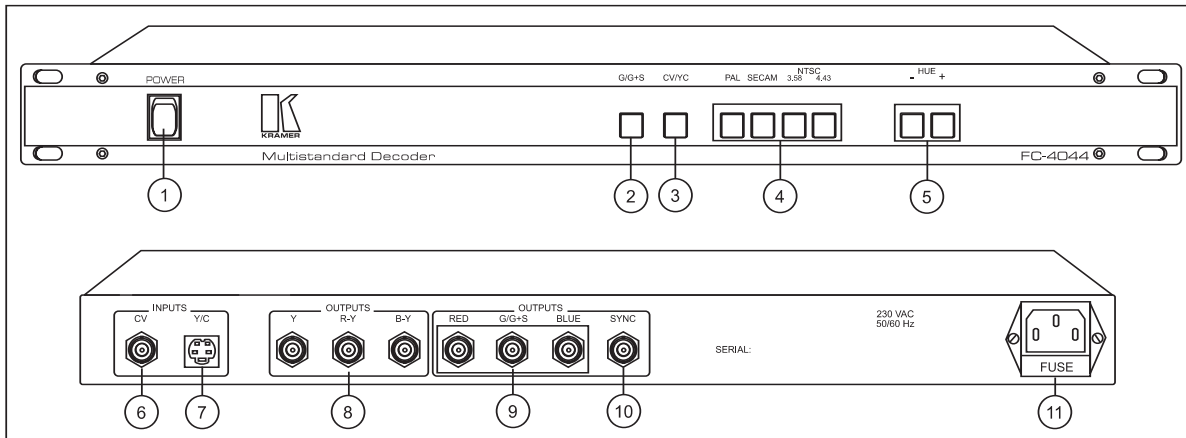

**Figure 7: FC-4044 Front/Rear Panel Features**

**Table 8: FC-4044- Front/Rear Panel Features**

	Feature	Function
1.	<b>Power Switch</b>	Illuminated switch supplies power to the unit.
2.	<b>G/G+S pushbutton</b>	Selects sync or sync on green on the <b>G/G+S</b> BNC connector.
3.	<b>CV/YC pushbutton</b>	Selects either composite video or YC input signal for conversion.
4.	<b>PAL, SECAM, 3.58, 4.43 pushbuttons</b>	Illuminated pushbuttons detect the existence of the following standards - <b>PAL, SECAM, NTSC 3.58 or 4.43</b> . <i>Pressing the buttons can force the decoder to accept the wrong standard and is therefore not recommended.</i>
5.	<b>HUE (+/-) pushbuttons</b>	Active when NTSC is used.
6.	<b>INPUTS CV BNC connector</b>	Composite video input.
7.	<b>INPUTS YC 4P connector</b>	<b>YC</b> input.
8.	<b>OUTPUTS Y, R-Y, B-Y BNC connector</b>	Component video outputs.
9.	<b>OUTPUTS RED, G/G+S, BLUE connectors</b>	RGB outputs ( <b>G</b> or <b>G+S</b> are selected via the <b>G/G+S</b> pushbutton).
10.	<b>OUTPUTS SYNC connector</b>	Composite sync output.
11.	<b>Power Connector</b>	A 3-prong AC connector allows power to be supplied to the unit. Directly underneath this connector, a fuse holder houses the appropriate fuse.



## 5.8 Getting to Know Your FC-4208

The KRAMER **FC-4208** Balanced/Unbalanced Audio Transcoder is a bi-directional, versatile tool, converting between the two most commonly used audio standards. The machine allows gain or attenuation while transcoding, to compensate for the 14dB change between IHF audio levels and the newly adopted, balanced DAT input levels. Very low noise and distortion components are used throughout the machine. The **FC-4208** has 4 balanced audio inputs on XLRs and 4 unbalanced audio outputs on the balanced to unbalanced channels, and 4 unbalanced inputs and 4 balanced audio outputs on XLRs on the unbalanced to balanced channels. Each set (8 all together) has an individual level control for perfect matching.

Front/Rear panel features of the **FC-4208** are described in Figure 8 and Table 9.

### NOTE

*For operation instructions refer to section 9.*

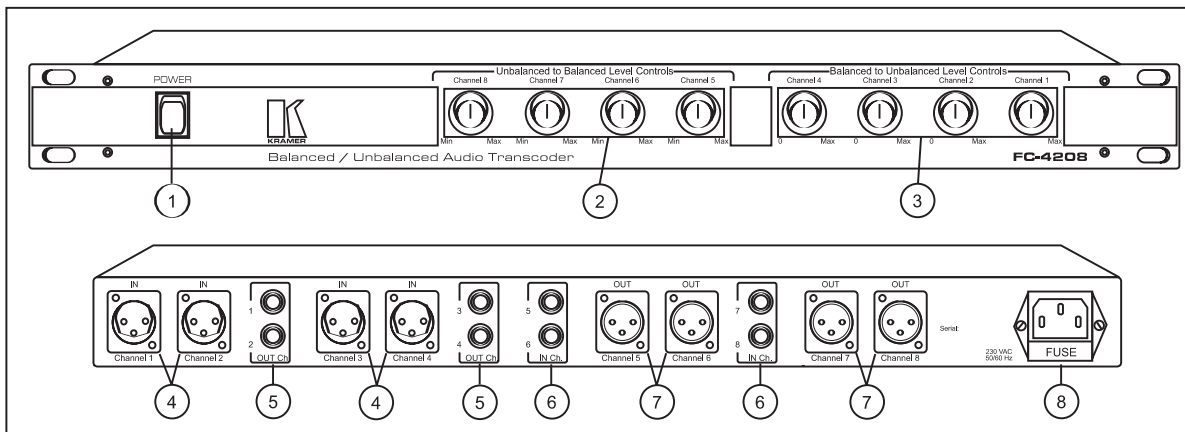

**Figure 8: FC-4208 Front/Rear Panel Features**

**Table 9: FC-4208 - Front/Rear Panel Features**

	Feature	Function
1.	<b>Power switch</b>	Illuminated switch supplies power to the unit.
2.	<b>Unbalanced to Balanced Level Controls</b>	Control the balanced audio level outputs.
3.	<b>Balanced to Unbalanced Level Controls</b>	Control the unbalanced audio level outputs.
4.	<b>IN Channel 1-4 XLR female connectors</b>	Balanced audio inputs.
5.	<b>OUT Ch RCA connectors</b>	Unbalanced audio outputs.
6.	<b>IN Ch RCA connectors</b>	Unbalanced audio inputs.
7.	<b>OUT Channel 5-8 XLR female connectors</b>	Balanced audio outputs.
8.	<b>Power Connector</b>	A 3-prong AC connector allows power to be supplied to the unit. Directly underneath this connector, a fuse holder houses the appropriate fuse.



---

## 6 INSTALLATION

### 6.1 Rack Mounting

The FC-19, FC-4041C, FC-4042, FC-4043, FC-4044 and FC-4208 may be rackmounted in a standard 19" (1U) EIA rack, and include rack "ears" at the ends of the front panel. To mount them, simply place the unit's ears against the rack rails of your rack, and insert standard screws through each of the four corner holes. The FC-10 and the FC-10D can be rack mounted using a special adapter (see section 4.1). These devices do not require any specific spacing for ventilation above or below the unit.

## 7 CONNECTING TO VIDEO DEVICES

Video sources and output devices (such as monitors, projectors or recorders) may be connected to the machines through the BNC and/or 4P type connectors located on the back of the units. Unused inputs are terminated to 75ohm, and active inputs should be terminated by the connecting source. All signal connections that use more than one cable interconnecting between devices should be of equal length. (Example: RGB cables between a camera and the machine should be equal in length.) The signals supported by the various models are: Composite Video, s-Video (Y/C), Component Video and Analog Red, Green, Blue and Sync signals (RGBS).

## 8 CONNECTING TO AUDIO DEVICES (FC-4208 only)

Audio sources and output devices (such as amplifiers or recorders) may be connected to the machine through the RCA or/and XLR type connectors located on the back of the machine.

## 9 USING THE MACHINES

### 9.1 Powering on the Machine

#### NOTES

- 1) The machine should only be powered on after all connections are completed and all source devices have been powered on. Do not attempt to connect or disconnect any video, audio or control signals to the machine while it is powered on!
- 2) The socket-outlet should be near the equipment and should be easily accessible. To fully disconnect equipment, remove power cord from socket.

1. Toggle the switch on the far-left front panel to the up position. The switch will glow.
2. Operate sources and the acceptors.

### 9.2 Composite/YC Video Selection (FC-19, FC-4043, FC-4044 only)

Selecting either Composite or Super video to be converted is simply done by using the **Select CV/YC** switch (FC-19) or the **CV/YC** pushbutton (FC-4043, FC-4044).

### 9.3 Adjusting the HUE (FC-4043, FC-4044 only)

The term "HUE" is often used synonymously with the term "tint". It is the dominant wavelength, which distinguishes a color or tint as red or yellow, etc. Video hue is influenced by several factors: Adjustment of the white balance of the camera, quality of the electronic equipment which is being used, and lighting of the scene. In the American NTSC standard, hue errors are more common than in the European PAL standard due to a different color encoding system. The PAL system compensates for color problems and corrects wrong hues during operation. Video color processors are needed to adjust and correct hue problems. To adjust the HUE, simply press the **HUE "+"** or **"-"** pushbuttons, until a satisfactory picture color is achieved.

### 9.4 Looping (FC-4041C only)

The looping function enables the operator to connect several machines to the format interface. The operator must always switch the termination switch of the **first** and **middle** machines to **"Hi-z"**. The **last** machine's termination switch should always be at **"75ohm"** to maintain well-matched lines (of 75ohm impedance) from the first to the last machine. Note that if the looping function is not used, the termination switch should be set to **"75 ohm"**.



## 9.5 Audio Level Control (FC-4208 only)

A balanced audio signal is made of two antiphase signals, traveling on two wires (sometimes with a third - a ground reference / shield wire). A balanced signal achieves better signal-to-noise ratio, and is more immune to noise and interference. On the receiving end there is a differential amplifier, which amplifies only the difference between the antiphase signals, thus canceling noise which is picked up along the way and which is common mode. The balanced system is usually used either when very low signals are to be transmitted over long distances (such as those generated from high quality microphones) or at broadcast audio studios, for highest quality signal recreation. To control the balanced/unbalanced signal, gently adjust the **Level** control knobs until a satisfactory audio level is achieved.

## 10 TYPICAL APPLICATIONS

### 10.1 Interfacing Between Two Video Formats

The FC-10D can be used for simultaneous bi-directional conversion from composite video to YC and from YC to composite for studio applications as shown in Figure 9. In such a setup, YC signals can be monitored on a composite video monitor! Perform the following steps (as necessary):

1. Connect a composite video source to the **CV IN** connector of the FC-10D.
2. Connect an YC acceptor to the **YC OUT** connector of the FC-10D.
3. Connect an YC video source to the **YC IN** connector of the FC-10D.
4. Connect a composite video acceptor to the **CV OUT** connector of the FC-10D.
5. Connect the FC-10D to an appropriate 12VDC power supply, with proper polarity.
6. Operate sources, acceptors and the FC-10D. Press one of the control switches to select PAL or NTSC mode of operation.

#### NOTE

*The machine cannot convert composite PAL to Y/C in NTSC. Encoding and decoding is performed only within the same standard.*

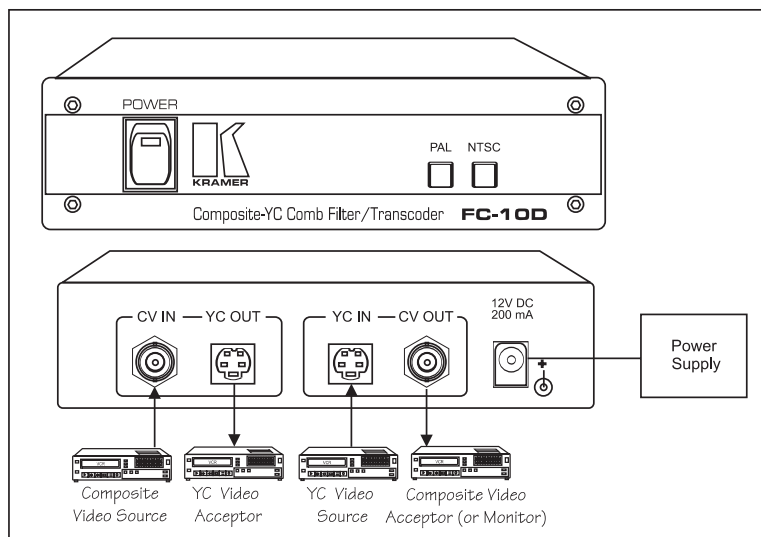
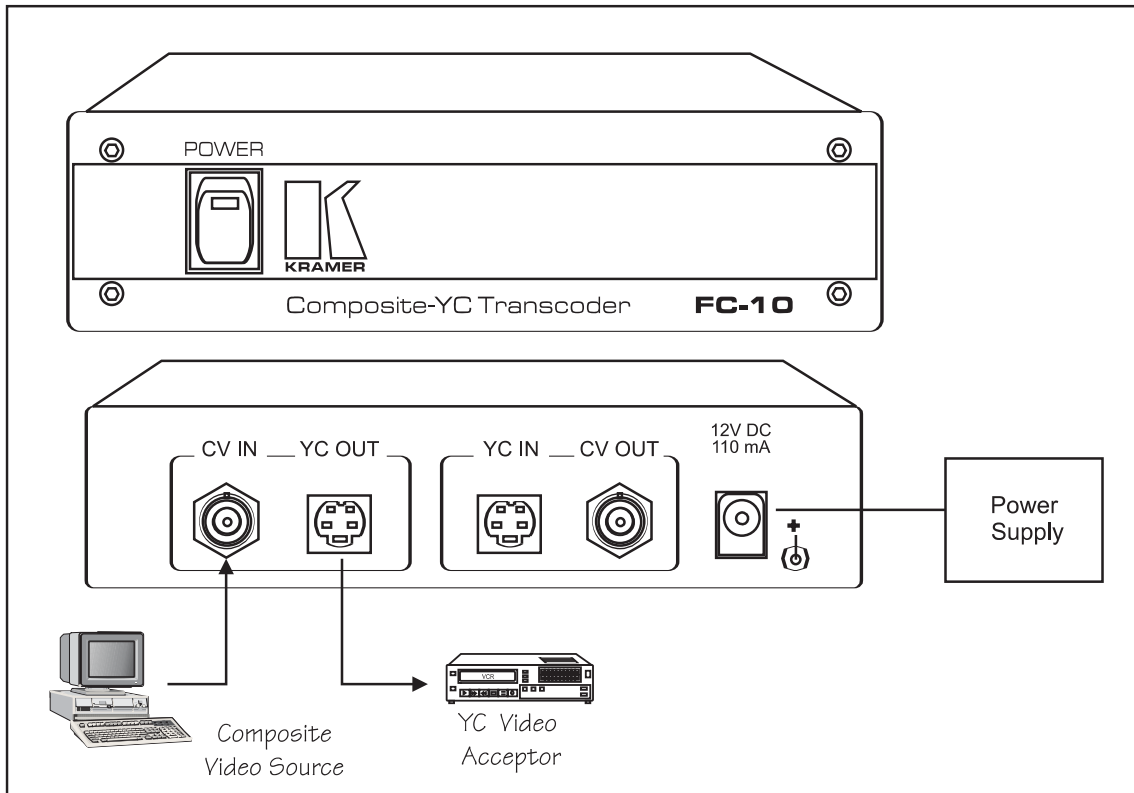

**Figure 9: Interfacing Between Two Video Formats**

### 10.2 Using PC Graphics in YC Production

Some scan converters, which convert VGA/XGA graphics to video, generate only a composite video signal. The FC-10 converts composite video signal to s-Video (YC), thus enabling usage of computer generated graphics in professional YC productions, as shown in Figure 10. Perform the following steps (as necessary):

1. Connect a composite video source to the **CV IN** BNC connector of the FC-10
2. Connect an YC acceptor to the **YC OUT** 4P connector of the FC-10.
3. Operate source, acceptor and the FC-10.



**Figure 10: Using PC Graphics in YC Production**

### 10.3 Typical Composite/YC to Component/RGB Conversion

Figure 11 illustrates a typical set up of the Kramer format converters described in this manual: incoming input signals from composite and YC (s-Video) sources are converted by a Multistandard Decoder (FC-4044, in this case) to component and RGB output signals, that are then sent to two different acceptors. A Chroma Keyer/Mixer may be connected in parallel to the RGB outputs in order to control the RGB display. A mixer is a device used to combine video signals from two or more sources. Synchronized inputs are mixed with each other and various special effects patterns and shapes are added in accordance with the proficiency of the video mixer being used.

Perform the following steps (as necessary):

1. Connect CV/YC sources to the inputs (FC-4044 in this case).
2. Connect the outputs to two different RGB/component acceptors.
3. Operate sources, acceptors and your machine.
4. Use the front panel control functions if necessary (see section 9 for more details).

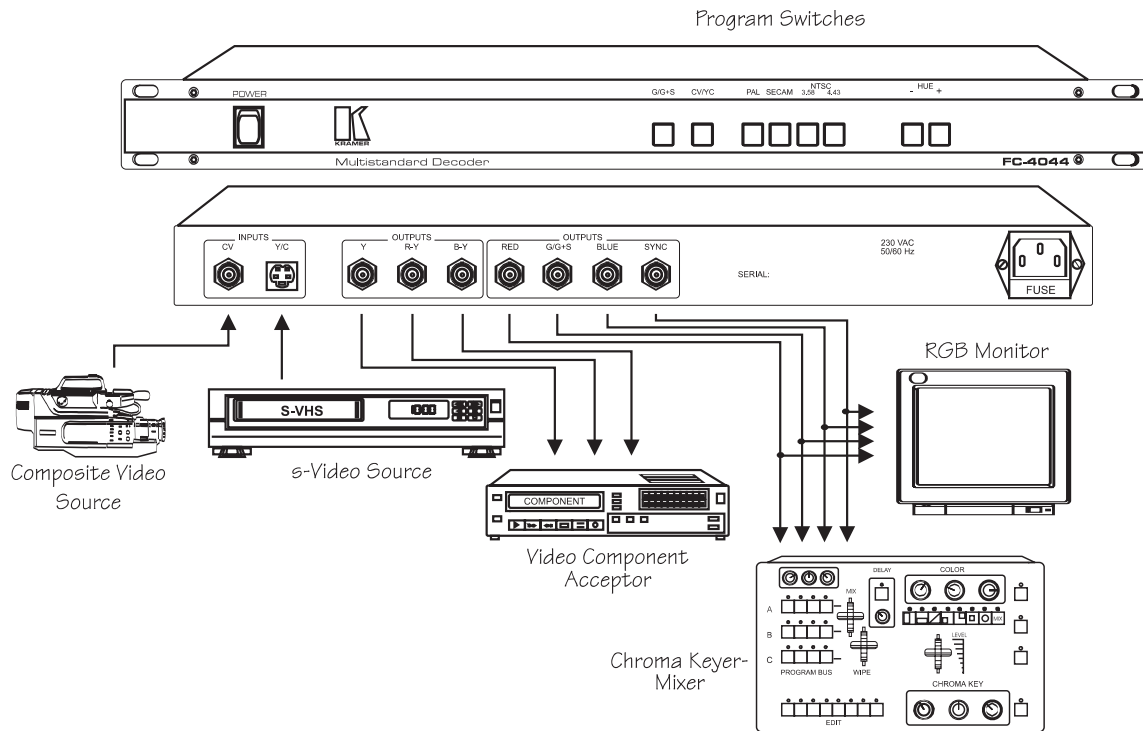

Figure 11: Typical PC/Presentation Product Connections

#### 10.4 Integrating a Composite/RGB source Into a Composite/YC Switcher

It is sometimes necessary for pre-edit purposes, to switch a component video source alongside composite or Y/C sources. Some but not all of the component video sources include a composite or a Y/C output. In order to perform the above-mentioned task, a video encoder is needed in order to convert either YUV or RGB signals to composite and Y/C signals, as shown in Figure 12.

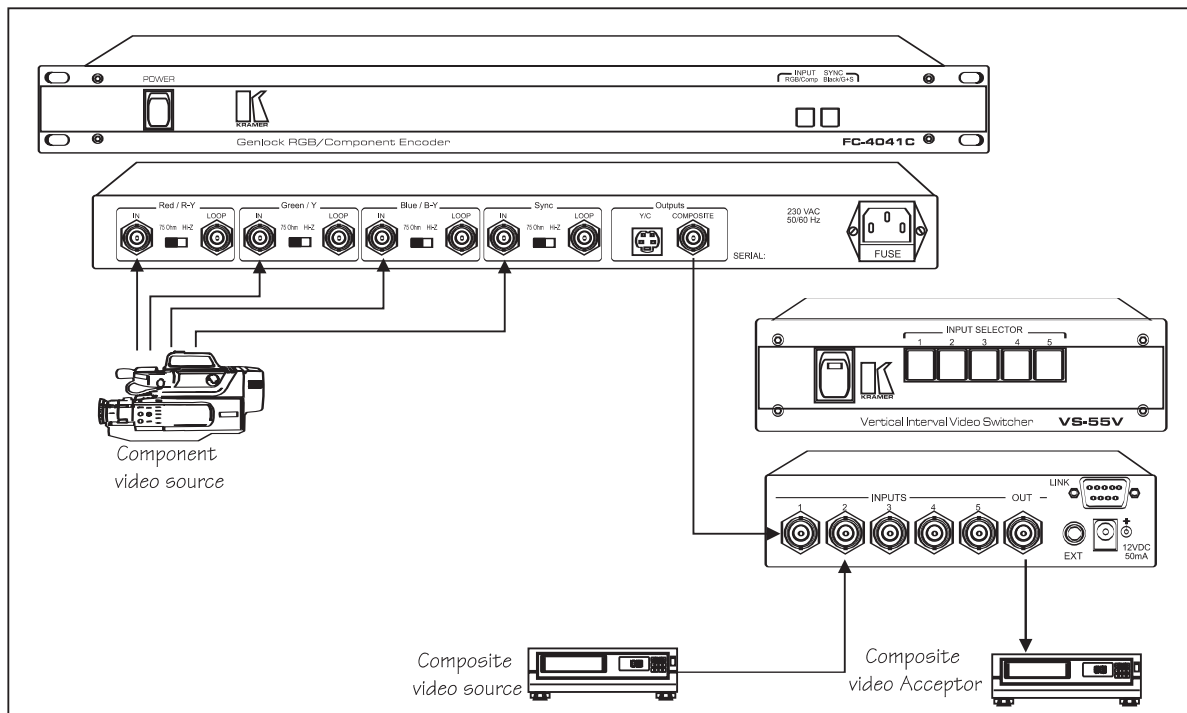

Figure 12: Integrating a Component/RGB Source Into a Composite/YC Switcher

## 10.5 Audio Format Conversion

Professional audio usually requires balanced audio signals that are less prone to interference due to the differential signal setup. When using unbalanced and balanced signals at the same setup, amplification or attenuation is needed to match the levels. An Audio Transcoder (FC-4208 in this case) can be used for this purpose and for signal conversion as well, as shown in Figure 13.

Perform the following steps (as necessary):

1. Connect one or more balanced audio sources to **Channel 1** and **Channel 2** XLR inputs of the FC-4208.
2. Connect one or more unbalanced audio sources to **Channel 1** and **Channel 2** RCA inputs of the FC-4208.
3. For unbalanced audio distribution, connect the outputs of the machine to an audio distributor (Kramer VM-50A for example.)
4. For balanced audio distribution, connect the outputs of the machine to a balanced audio distributor (Kramer VM-1110 for example.)
5. Operate sources, acceptors and your machine.
6. Use the front panel control functions if necessary (see section 9 for more details).

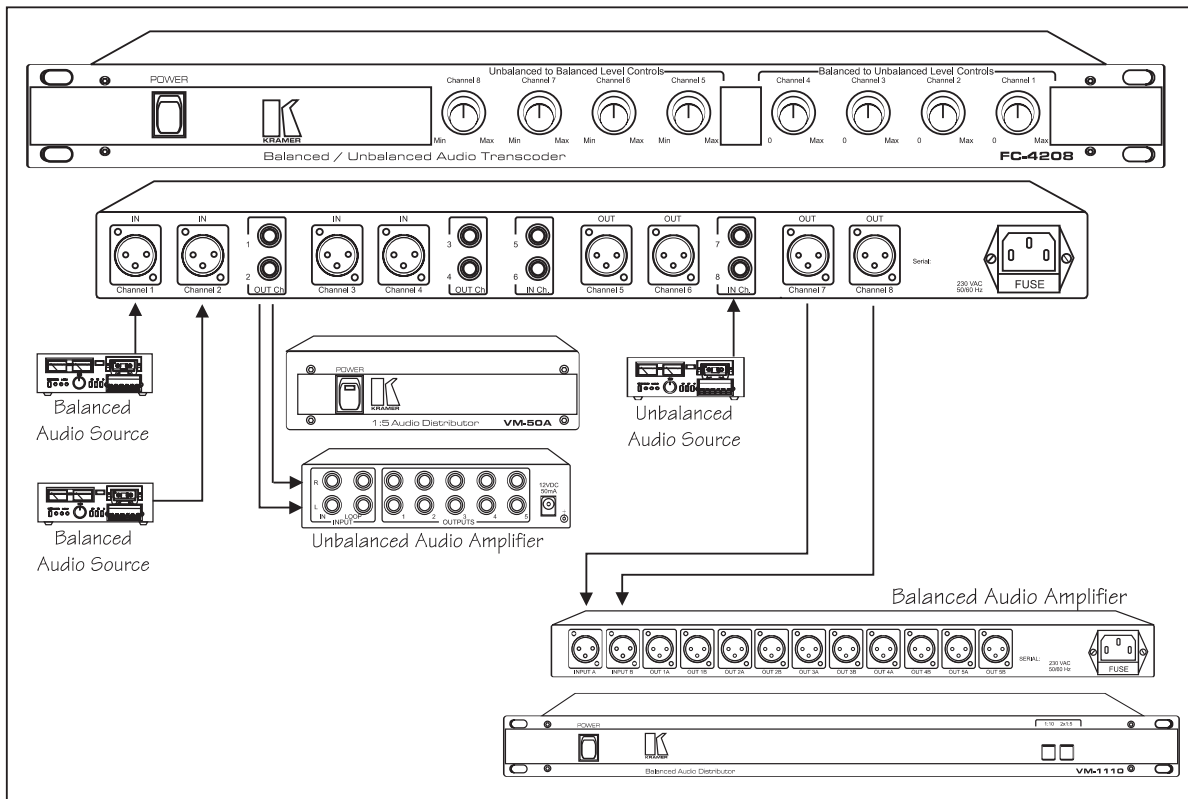

Figure 13: Audio Format Conversion

## 11 TAKING CARE OF YOUR MACHINE

Do not locate your machine in an environment where it is susceptible to dust or moisture. Both of these may damage the electronics, and cause erratic operation or failure. Do not locate your machine where temperature and humidity may be excessive. Doing so may also damage the electronics, and cause erratic operation or failure of your machine. Do not clean your machine with abrasives or strong cleaners. Doing so may remove or damage the finish, or may allow moisture to build up. Take care not to allow dust or particles to build up inside unused or open connectors.



## 12 TROUBLESHOOTING

### NOTES

1. Please note that if the output signal is disturbed or interrupted by very strong external electromagnetic interference, it should return and stabilize when such interference ends. If not, turn the power switch off and on again to reset the machine.
2. If the following recommended actions do not result in satisfactory operation, please consult your KRAMER Dealer.

### 12.1 Power and Indicators

Problem	Remedy
<p><b>No Power</b></p>	<ol style="list-style-type: none"> <li>1. Confirm that the rocker switch is in the "ON" position, and that the lamp is illuminated.</li> <li>2. Confirm that power connections are secured at the machine and at the receptacle. Make sure the mains receptacle is active (FC-19, FC4041C, FC-4042, FC-4043, FC-4044, FC-4208) or that the DC power supply is operational (FC-10, FC-10D).               <ul style="list-style-type: none"> <li>➤ <b>For the Mains operated models perform the following:</b> <ol style="list-style-type: none"> <li>1. If there is no power, remove power cord from AC outlet and then using a flat head screwdriver, remove the fuse holder located directly below the power connector on your machine.</li> <li>2. Confirm that the fuse is good by looking for the wire connected between the ends of the fuse. If the wire is broken, replace the fuse with another, with the same rating.</li> </ol> </li> <li>➤ <b>For the DC operated models perform the following:</b> <ol style="list-style-type: none"> <li>1. Using a Philips screwdriver, remove the 4 side screws attaching the machine's cover (see below).</li> </ol> </li> </ul> </li> </ol> <div data-bbox="548 1220 1378 1680" style="border: 1px solid black; padding: 10px; margin: 10px 0;"> </div> <ol style="list-style-type: none"> <li>2. Locate the fuse holder inside your machine (see Figure 14). Confirm that the fuse is good by looking for the wire connected between the ends of the fuse. If this wire is broken, replace the fuse with another, with the same rating.</li> <li>3. Install cover by replacing the Philips screws.</li> </ol>

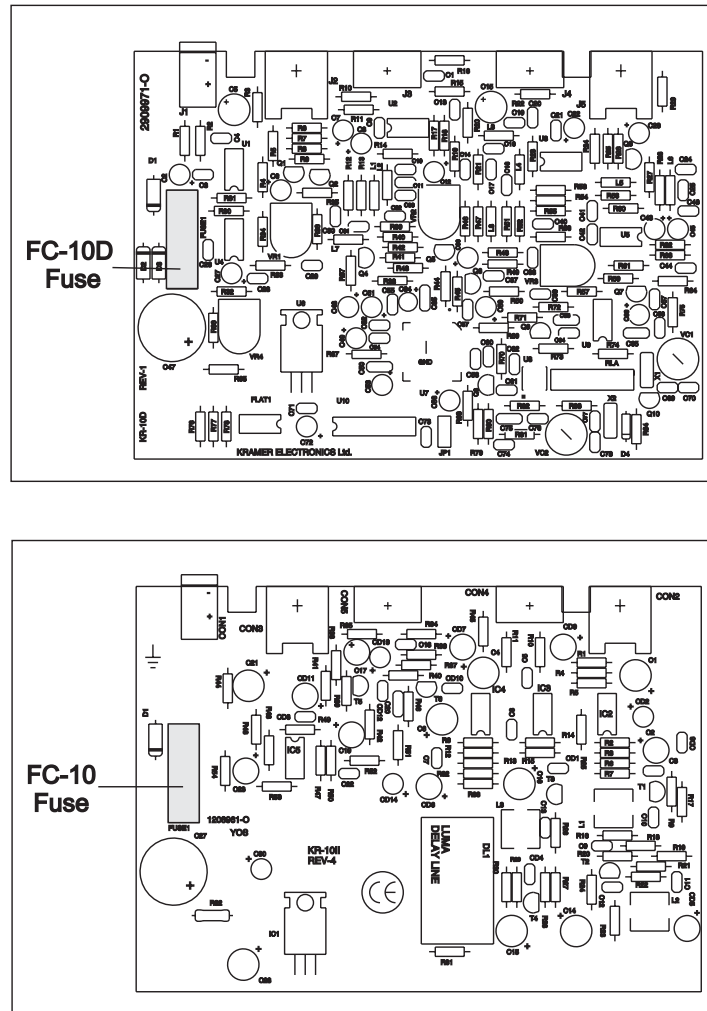

Figure 14: FC-10 and FC-10D Fuse Location

## 12.2 Video Signal

Problem	Remedy
<b>No video at the output device</b>	<ol style="list-style-type: none"> <li>1. Confirm that your source and output devices are powered on and connected properly. The input of your machine should be of an identical signal format at the output of your source. Signals at the output of your machine should be of an identical signal format as at the input of your display.</li> <li>2. Confirm that any other device in the signal path has the proper input and/or output selected.</li> <li>3. Use a Video Tester to help trace faulty cables and equipment (see section 4.1 "Optional Accessories")</li> </ol>
<b>Video level is too high or too dim.</b>	<ol style="list-style-type: none"> <li>1. Verify that the lines are well matched through 75ohm impedances; otherwise it results in a video level that is too high or too dim.</li> <li>2. Confirm that the connecting cables are of high quality and properly inserted.</li> <li>3. Check level controls located on your source input device or output display.</li> </ol>



### Video Signal (continued)

Problem	Remedy
<p>Noise bars are "rolling" up or down in the output image</p> <p>or:</p> <p>Low Frequency Hum in the output signal</p>	<p>Hum bars (ground loop) are caused by a difference in the ground potential of any two or more devices connected to your signal path. This difference is compensated by passing that voltage difference through any available interconnection, including your video cables.</p> <p style="text-align: center;"><b>WARNING!</b></p> <p style="text-align: center;"><i>Do not disconnect the ground from any piece of video equipment in your signal path!</i></p> <p>Check the following to remove hum bars:</p> <ol style="list-style-type: none"><li>1. Confirm that all interconnected equipment is connected to the same phase of power, if possible.</li><li>2. Remove equipment connected to that phase that may introduce noise, such as motors, generators, etc.</li><li>3. Disconnect all interconnect cables and reconnect them one at a time until ground loop reappears. Disconnect the affected cable and replace, or insert an isolation transformer in the signal path.</li></ol>

### 12.3 Audio Signal (FC-4208 only)

Problem	Remedy
<p>No audio at the output device, regardless of input selected</p>	<ol style="list-style-type: none"><li>1. Confirm that your source and output devices are powered and properly connected. Audio signals connected to the output of your machine should be properly wired to the input of your machine or recorder.</li><li>2. Confirm that any other devices in the signal path has the proper input and/or output selected.</li></ol>
<p>Audio level is too low</p>	<ol style="list-style-type: none"><li>1. Confirm that the connecting cables are of high quality and properly built. Take special care in noting the wiring configuration of balanced to unbalanced cables.</li><li>2. Check level controls located on your source input device or output display or recorder.</li></ol>



---

## **LIMITED WARRANTY**

Kramer Electronics (hereafter Kramer) warrants this product to be free from defects in material and workmanship under the following terms.

### **HOW LONG IS THE WARRANTY**

Labor and parts are warranted for three years from the date of the first customer purchase.

### **WHO IS PROTECTED**

Only the first purchase customer may enforce this warranty.

### **WHAT IS COVERED AND WHAT IS NOT COVERED**

Except as below, this warranty covers all defects in material or workmanship in this product. The following are not covered by the warranty:

- 1) Any product which is not distributed by Kramer, or which is not purchased from an authorized Kramer dealer. If you are uncertain as to whether a dealer is authorized, please contact Kramer at one of the agents listed in the web site **www.kramerelectronics.com**.
- 2) Any product, on which the serial number has been defaced, modified or removed.
- 3) Damage, deterioration or malfunction resulting from:
  - a) Accident, misuse, abuse, neglect, fire, water, lightning or other acts of nature.
  - b) Product modification, or failure to follow instructions supplied with the product.
  - c) Repair or attempted repair by anyone not authorized by Kramer.
  - d) Any shipment of the product (claims must be presented to the carrier).
  - e) Removal or installation of the product.
  - f) Any other cause, which does not relate to a product defect.
  - g) Cartons, equipment enclosures, cables or accessories used in conjunction with the product.

### **WHAT WE WILL PAY FOR AND WHAT WE WILL NOT PAY FOR**

We will pay labor and material expenses for covered items. We will not pay for the following:

- 1) Removal or installations charges.
- 2) Costs of initial technical adjustments (set-up), including adjustment of user controls or programming. These costs are the responsibility of the Kramer dealer from whom the product was purchased.
- 3) Shipping charges.

### **HOW YOU CAN GET WARRANTY SERVICE**

- 1) To obtain service on you product, you must take or ship it prepaid to any authorized Kramer service center.
- 2) Whenever warranty service is required, the original dated invoice (or a copy) must be presented as proof of warranty coverage, and should be included in any shipment of the product. Please also include in any mailing a contact name, company, address, and a description of the problem(s).
- 3) For the name of the nearest Kramer authorized service center, consult your authorized dealer.



---

## LIMITATION OF IMPLIED WARRANTIES

All implied warranties, including warranties of merchantability and fitness for a particular purpose, are limited in duration to the length of this warranty.

## EXCLUSION OF DAMAGES

Kramer's liability for any defective products is limited to the repair or replacement of the product at our option. Kramer shall not be liable for:

- 1) Damage to other property caused by defects in this product, damages based upon inconvenience, loss of use of the product, loss of time, commercial loss; or:
- 2) Any other damages, whether incidental, consequential or otherwise. Some countries may not allow limitations on how long an implied warranty lasts and/or do not allow the exclusion or limitation of incidental or consequential damages, so the above limitations and exclusions may not apply to you.

This warranty gives you specific legal rights, and you may also have other rights, which vary from place to place.

**NOTE:** All products returned to Kramer for service must have prior approval. This may be obtained from your dealer.

---

## NOTICE

This equipment has been tested to determine compliance with the requirements of:

- EN-50081:** "Electromagnetic compatibility (EMC);  
generic emission standard.  
Part 1: Residential, commercial and light industry"
- EN-50082:** "Electromagnetic compatibility (EMC) generic immunity standard. Part 1:  
Residential, commercial and light industry environment".
- CFR-47** FCC Rules and Regulations:  
Part 15- "Radio frequency devices:  
Subpart B- Unintentional radiators"

## CAUTION

- Servicing the machines can only be done by an authorized Kramer technician. Any user who makes changes or modifications to the unit without the expressed approval of the manufacturer will void user authority to operate the equipment.
- Use the supplied AC power cord (when applicable) to supply power to the machine and controllers.
- Please use recommended interconnect cables to connect the machine to controllers and other components.



---

**For the latest information on our products and a list of  
Kramer distributors, visit our Web site:  
[www.kramerelectronics.com](http://www.kramerelectronics.com).  
Updates to this user manual may be found at  
<http://www.kramerelectronics.com/manuals.html>.  
We welcome your questions, comments and feedback.**



---

**Kramer Electronics, Ltd.**  
Web site: [www.kramerelectronics.com](http://www.kramerelectronics.com)  
E-mail: [info@kramerelect.com](mailto:info@kramerelect.com)  
P/N: 2900-004001 REV 2