



MODEL BETA 56®A COMPACT SUPERCARDIOID DYNAMIC MICROPHONE

GENERAL

The compact Shure BETA 56®A is a high output supercardioid dynamic microphone designed for professional sound reinforcement and project studio recording. Its extremely uniform supercardioid pickup pattern provides high gain before feedback and excellent rejection of unwanted noise. A built-in dynamic locking stand adapter with an integral XLR connector simplifies installation. The stand adapter keeps the microphone securely in place, even if it is struck by a drumstick. Typical BETA 56A applications include close miking of tom-toms and other percussion instruments, as well as guitar amplifiers, brass instruments, and woodwinds.

FEATURES

- Tailored frequency response provides drums, amplified instruments, and horns with studio quality sound
- Built-in stand adapter with dynamic locking system and XLR connector simplifies setup and provides greater flexibility
- Uniform supercardioid pattern for high gain before feedback and superior rejection of off-axis sound
- Compact design reduces stage clutter
- Hardened steel mesh grille resists wear and abuse
- Neodymium magnet for high signal-to-noise ratio output
- Minimally affected by varying load impedance
- Advanced pneumatic shock mount system that minimizes transmission of mechanical noise and vibration
- Legendary Shure quality and reliability

GENERAL RULES FOR MICROPHONE USE

1. Aim the microphone toward the desired sound source and away from unwanted sources. This may not be obvious or intuitive, since supercardioid microphones such as the BETA 56A have narrow pickup patterns and can pick up sounds from the rear. Refer to Figure 1 on the following page.
2. Place the microphone as close as practical to the desired sound source (refer to the table in the opposite column).
3. Work close to the microphone for extra bass response.
4. Use only one microphone to pick up a single sound source.
5. Use the fewest number of microphones as practical.
6. Keep multiple microphones separated by a distance equal to at least 3X the distance to the nearest sound source.
7. Place mics as far as possible from reflective surfaces.
8. Use a windscreen when using the microphone outdoors.

BETA 56A APPLICATIONS AND PLACEMENT

The most common BETA 56A applications and placement techniques are listed in the following table. Keep in mind that microphone technique is largely a matter of personal taste; there is no one “correct” microphone position.

APPLICATION	SUGGESTED MICROPHONE PLACEMENT	STONE QUALITY
Tom-Toms	One BETA 56A on each tom, or between each pair of toms, 2.5 to 7.5 cm (1 to 3 in.) above drum heads. Aim each mic at top drum heads. On double head toms, you can also remove bottom head and place a mic inside pointing up toward top drum head.	Medium attack; full, balanced sound. Medium attack; full, balanced sound.
Snare Drum	2.5 to 7.5 cm (1 to 3 in.) above rim of top head of drum. Aim mic at drum head. If desired, place a second mic just below rim of bottom head.	Most “snap” from drumstick. More “snare” sound.
Guitar & Bass Amplifiers	2.5 cm (1 in.) from speaker, on-axis with center of speaker cone. 2.5 cm (1 in.) from speaker, at edge of speaker cone. 15 to 30 cm (6 to 12 in.) away from speaker and on-axis with speaker cone. 60 to 90 cm (2 to 3 ft.) back from speaker, on-axis with speaker cone.	Sharp attack; emphasized bass. Sharp attack; higher frequency sound. Medium attack; full, balanced sound. Softer attack; reduced bass.
Brass & Woodwinds	Brass: 30 to 90 cm (1 to 3 ft.) away, on-axis with bell of instrument. Woodwinds: 2.5 to 15 cm (1 to 6 in.) away, on-axis with bell of instrument. Bell of instrument 90° off-axis from front of mic.	Bright, clear sound. Bright, clear sound. Softer, mellow sound.

MOUNTING THE BETA 56A ON A MICROPHONE STAND

The built-in stand adapter features a **dynamic locking system** that permits adjustments to the microphone’s position, but resists slipping when struck by drumsticks. To mount the BETA 56A on a stand and adjust its position, proceed as follows:

1. Screw the integral stand adapter onto the end of a microphone stand (see Figure 4). Adjust the stand height and position as necessary. Make sure the adjustment knob on the adapter is loose.
2. Pivot the BETA 56A until it is in the desired position relative to the drum head or instrument speaker.
3. Lock the BETA 56A in place by rotating the thumbscrew on the stand adapter clockwise until it is tight. Do NOT use tools to overtighten the adjustment knob.
4. If necessary, make minor adjustments to the microphone position without loosening the adjustment knob.
5. Connect an audio cable to the integral XLR connector.

STAGE MONITOR AND P.A. LOUDSPEAKER PLACEMENT

For maximum rejection of unwanted sound, place the stage monitor(s) or P.A. system loudspeakers at a 60° angle from the rear of the BETA 56A, *not* directly behind it (see Figure 1). Always check out the stage setup before a performance to ensure optimum placement of microphone and monitors.

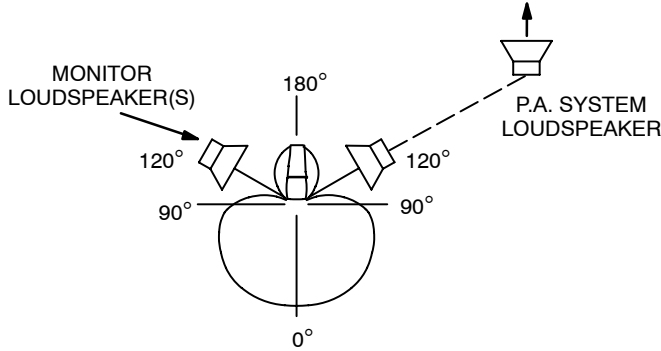

RECOMMENDED LOUDSPEAKER LOCATIONS
FIGURE 1

SPECIFICATIONS

Type

Dynamic (moving coil)

Frequency Response

50 to 16,000 Hz (see Figure 2)

NOTE: The curve below shows on-axis response at a distance of 2 feet from a uniform sound source. Your response may vary, depending on microphone position.

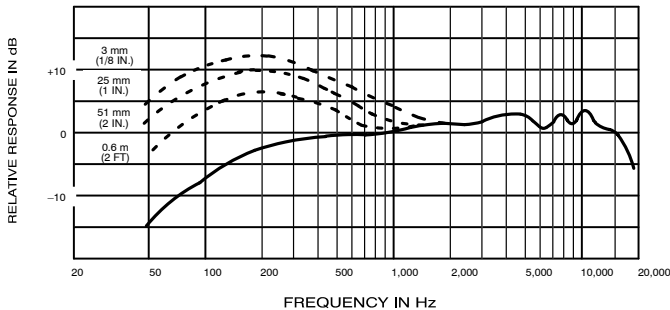

TYPICAL FREQUENCY RESPONSE
FIGURE 2

Polar Pattern

Supercardioid, rotationally symmetrical about microphone axis, uniform with frequency (see Figure 3)

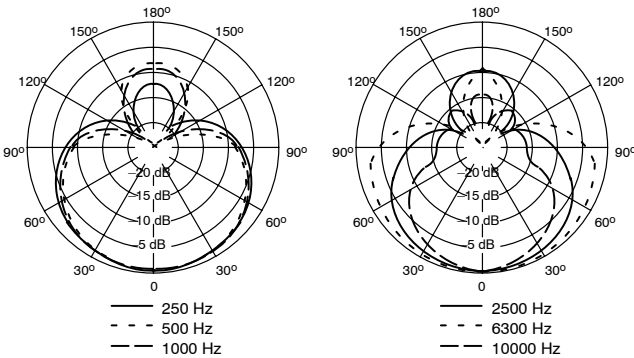

TYPICAL POLAR PATTERNS
FIGURE 3

Output Level (at 1,000 Hz)

Open Circuit Voltage -51 dBV/Pa (2.8 mV)
(1 Pa = 94 dB SPL)

Impedance

Rated impedance is 150 Ω (290 Ω actual) for connection to microphone inputs rated low Z

Polarity

Positive pressure on diaphragm produces positive voltage on pin 2 with respect to pin 3

Connector

Three-pin professional audio connector (male XLR type)

Case

Silver blue enamel-painted die cast metal with hardened, matte-finished steel mesh grille

Adjustable, Locking Stand Adapter

Integral, dynamic locking, adjustable through 180°, with standard 5/8"-27 thread (see Figure 4)

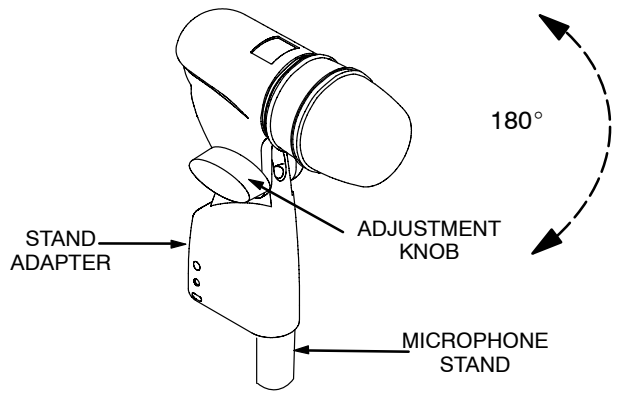

BUILT-IN BETA 56A STAND ADAPTER
FIGURE 4

Net Weight

468 grams (16.7 oz)

CERTIFICATION

Eligible to bear CE Marking. Conforms to European EMC Directive 89/336/EEC. Meets applicable tests and performance criteria in European Standard EN55103 (1996) parts 1 and 2, for residential (E1) and light industrial (E2) environments.

FURNISHED ACCESSORIES

- 5/8" to 3/8" (Euro) Thread Adapter 95A2050
- Storage Bag 26A21

OPTIONAL ACCESSORIES

- Windscreen A1WS
- 7.6 m (25 ft.) Cable C25E, C25F

REPLACEMENT PARTS

- Cartridge R174
- Grille Assembly RK320
- Plug (Connector) Assembly 90F1984



For more information or to order call

1-800-426-8664 or visit **www.ccisolutions.com**